



DEPARTMENT OF REGULATORY AND ECONOMIC RESOURCES (RER)
BOARD AND CODE ADMINISTRATION DIVISION

NOTICE OF ACCEPTANCE (NOA)

MIAMI-DADE COUNTY
PRODUCT CONTROL SECTION
11805 SW 26 Street, Room 208
Miami, Florida 33175-2474
T (786) 315-2590 F (786) 315-2599
www.miamidade.gov/economy

FastPlank, Inc.
4115 72nd Avenue S.E.
Calgary, Alberta, T2C 2G5

SCOPE: This NOA is being issued under the applicable rules and regulations governing the use of construction materials. The documentation submitted has been reviewed and accepted by Miami-Dade County RER-Product Control Section to be used in Miami-Dade County and other areas where allowed by the Authority Having Jurisdiction (AHJ).

This NOA shall not be valid after the expiration date stated below. The Miami-Dade County Product Control Section (In Miami-Dade County) and/or the AHJ (in areas other than Miami-Dade County) reserve the right to have this product or material tested for quality assurance purposes. If this product or material fails to perform in the accepted manner, the manufacturer will incur the expense of such testing and the AHJ may immediately revoke, modify, or suspend the use of such product or material within their jurisdiction. RER reserves the right to revoke this acceptance if it is determined by Miami-Dade County Product Control Section that this product or material fails to meet the requirements of the applicable building code.

This product is approved as described herein and has been designed to comply with the Florida Building Code, including the High Velocity Hurricane Zone.

DESCRIPTION: FastPlank 6" and 4" V-Notch Aluminum Siding and Vented Soffit

APPROVAL DOCUMENT: Drawing No. 0093-5965-SK2, titled "FastPlank Systems Aluminum Exterior Wall Cladding-Assembly Details in Florida HVHZ", sheets 1 through 11 of 11, dated 10/31/2024, prepared by the Boca Engineering Co., signed and sealed by Christopher W.C. Bowness, P.E., bearing the Miami-Dade County Product Control revision stamp with the Notice of Acceptance number and approval date by the Miami-Dade County Product Control Section.

MISSILE IMPACT RATING: Large and Small Missile Impact Resistant

LABELING: A permanent label with the manufacturer's name or logo, manufacturing plant's city and state, model/series, and the statement reading 'Miami-Dade County Product Control Approved' is to be located on each panel.

RENEWAL of this NOA shall be considered after a renewal application has been filed and there has been no change in the applicable building code negatively affecting the performance of this product.

TERMINATION of this NOA will occur after the expiration date or if there has been a revision or change in the materials, use, and/or manufacture of the product or process. Misuse of this NOA as an endorsement of any product, for sales, advertising or any other purposes shall automatically terminate this NOA. Failure to comply with any section of this NOA shall be cause for termination and removal of NOA.

ADVERTISEMENT: The NOA number preceded by the words Miami-Dade County, Florida, and followed by the expiration date may be displayed in advertising literature. If any portion of the NOA is displayed, then it shall be done in its entirety.

INSPECTION: A copy of this entire NOA shall be provided to the user by the manufacturer or its distributors and shall be available for inspection at the job site at the request of the Building Official.

This NOA revises NOA # 22-0615.01 and consists of this page 1 and evidence pages E-1 and E-2, as well as approval document mentioned above.

The submitted documentation was reviewed by **Carlos M. Utrera, P.E.**

DRAFT

NOA No. 24-0808.02
Expiration Date: April 6, 2028
Approval Date:
Page 1

NOTICE OF ACCEPTANCE: EVIDENCE SUBMITTED

A. DRAWINGS

1. Drawing No. **0093**, titled “Fastplank Systems Assembly Details in Florida HVHZ”, sheets 1 through 8 of 8, dated 08/19/2022, prepared by the Boca Engineering Co., signed and sealed by Christopher W.C. Bowness, P.E.

B. TESTS

1. Test reports on 1) Uniform Static Air Pressure Test, Loading per FBC TAS 202-94
2) Large Missile Impact Test per FBC, TAS 201-94
3) Cyclic Wind Pressure Loading per FBC, TAS 203-94
along with marked-up drawings of 6” Aluminum FastPlank Siding, prepared by Intertek, Test Report No. **104352869COQ-003A**, dated 10/14/2021, signed and sealed by Tyler Westerling, P.E.

C. CALCULATIONS

1. Stud deflection and fastener withdrawal calculations, prepared by Boca Engineering Co., dated 07/20/2022, signed and sealed by Christopher W.C. Bowness, P.E.

D. QUALITY ASSURANCE

1. Miami-Dade Department of Regulatory and Economic Resources (RER).

E. MATERIAL CERTIFICATIONS

1. None.

F. STATEMENTS

1. Statement letter of code conformance to the 7th edition (2020) of the FBC and of no financial interest issued by Boca Engineering Co., dated 07/25/2022, signed and sealed by Christopher W.C. Bowness, P.E.
3. Distributor agreement dated 03/13/2023.

Carlos M. Utrera, P.E.
Product Control Examiner
NOA No. 24-0808.02
Expiration Date: April 6, 2028
Approval Date:

NOTICE OF ACCEPTANCE: EVIDENCE SUBMITTED

A. DRAWINGS

1. Drawing No**0093-5965-SK2**, titled “FastPlank Systems Aluminum Exterior Wall Cladding-Assembly Details in Florida HVHZ”, sheets 1 through 11 of 11, dated 10/31/2024, prepared by the Boca Engineering Co., signed and sealed by Christopher W.C. Bowness, P.E.

B. TESTS

1. Test reports on 1) Uniform Static Air Pressure Test, Loading per FBC TAS 202-94
2) Cyclic Wind Pressure Loading per FBC, TAS 203-94
along with marked-up drawings of FastPlank P46V-Notch 6” Siding, prepared by Intertek, Test Report No. **1057450990COQ-001B**, dated 04/25/2024, with revision dated 06/03/2024, signed and sealed by Tyler Westerling, P.E.
2. Test reports on 1) Uniform Static Air Pressure Test, Loading per FBC TAS 202-94
2) Cyclic Wind Pressure Loading per FBC, TAS 203-94
along with marked-up drawings of FastPlank P46V-Notch 6” Siding w/ FastPlank P47V V-Notch 4” Soffit, prepared by Intertek, Test Report No. **105642282COQ-006**, dated 04/25/2024, signed and sealed by Tyler Westerling, P.E.
3. Test report on Wind Driven Rain Test, per FBC, TAS 100(A)-23, prepared by Intertek, dated 04/17/2024 and revised on 10/28/2024, signed and sealed by Tanya A. Dolby, P.E.

C. CALCULATIONS

1. Anchoring calculations, prepared by Boca Engineering Co., dated 10/04/2024, signed and sealed by Christopher W.C. Bowness, P.E.

D. QUALITY ASSURANCE

1. Miami-Dade Department of Regulatory and Economic Resources (RER).

E. MATERIAL CERTIFICATIONS

1. None.

F. STATEMENTS

1. Statement letter of code conformance to the 8th edition (2023) of the FBC and of no financial interest issued by Boca Engineering Co., dated 09/11/2024, signed and sealed by Christopher W.C. Bowness, P.E.

Carlos M. Utrera, P.E.
Product Control Examiner
NOA No. 24-0808.02
Expiration Date: April 6, 2028
Approval Date:

FASTPLANK SIDING AND SOFFIT

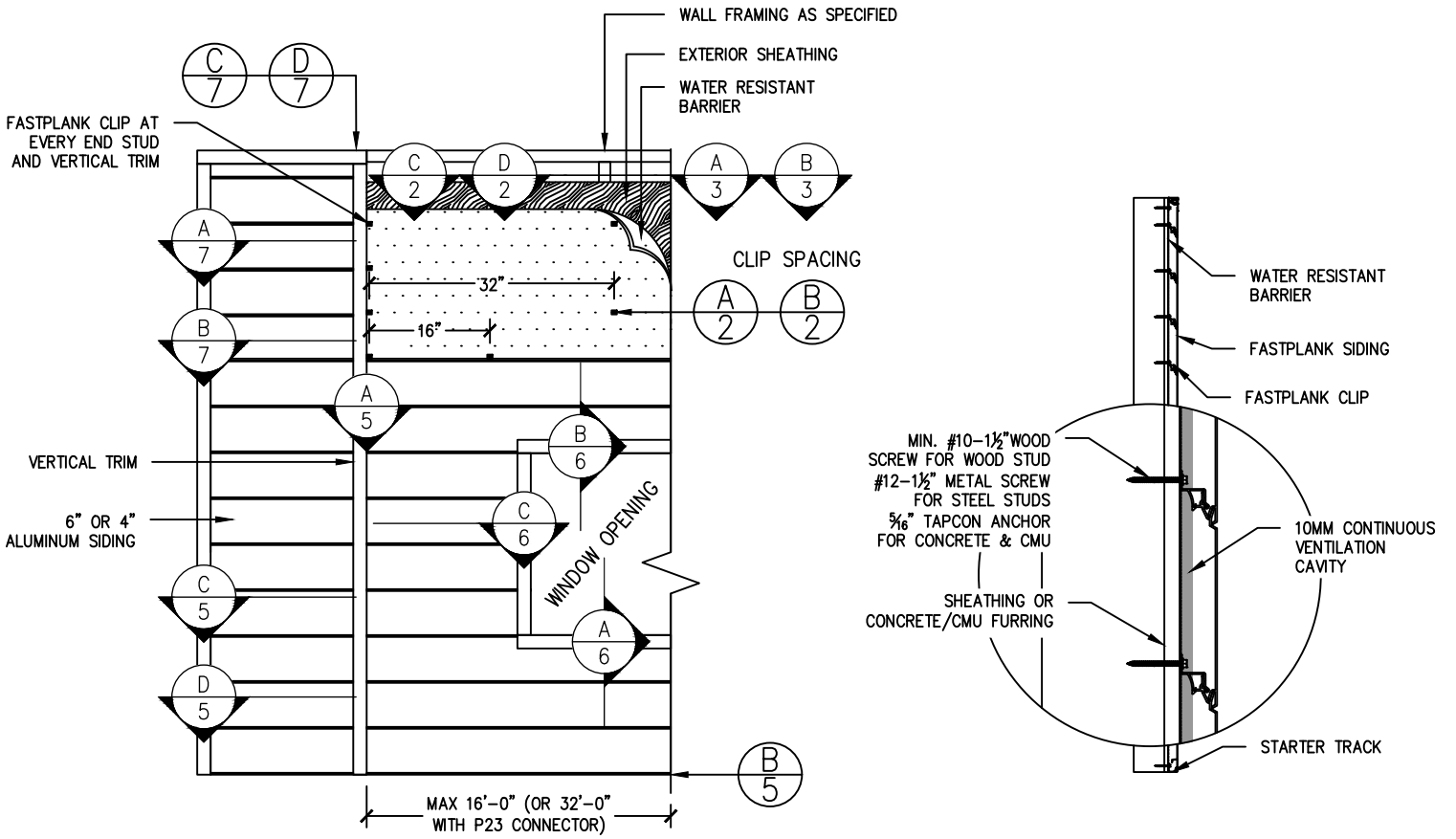

A
1 FASTPLANK WALL ELEVATION
NOT-TO-SCALE | ELEVATION

B
1 FASTPLANK ELEVATION
NOT-TO-SCALE | ELEVATION

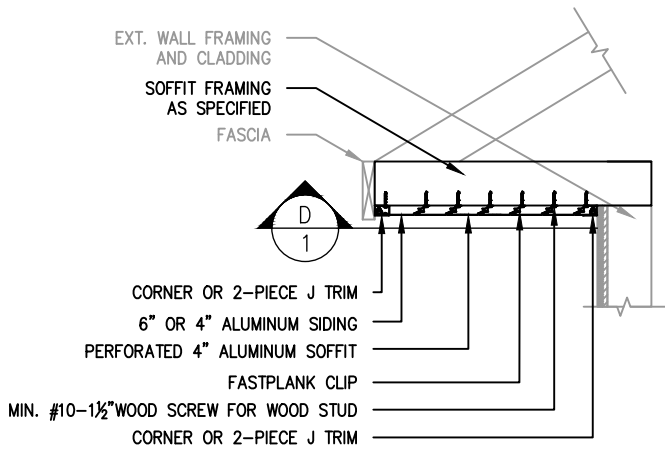

C
1 FASTPLANK SOFFIT ELEVATION
NOT-TO-SCALE | ELEVATION

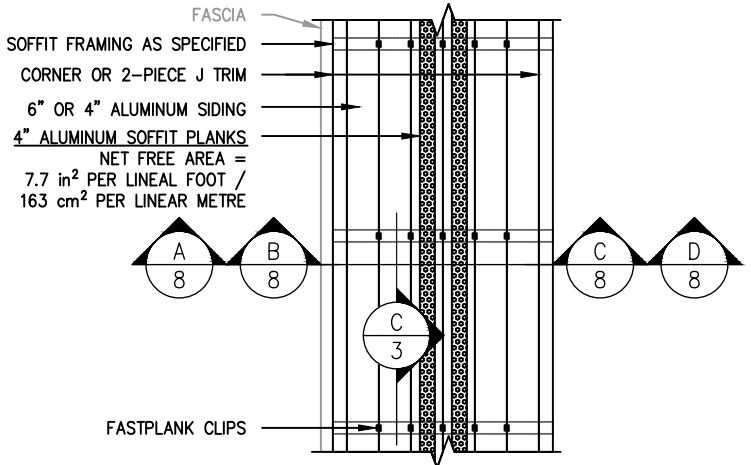

D
1 CLIPS AT 24" O.C STRAIGHT
NOT-TO-SCALE | BOTTOM VIEW



BOCA ENGINEERING
STRUCTURAL AND CIVIL ENGINEERS
#203-1001 CLOVERDALE AVE, VICTORIA BC
V8X 4C9 250-477-7777
INFO@BOCAENGINEERING.COM
WWW.BOCAENGINEERING.COM

DATE	1		FOR PUBLICATION	CB
	OCTOBER 31, 2024		REV.	ISSUE
DRAWING NO.	PAGE NO.	SCALE	DES.	DRN.
0093-5965-SK2	1 OF 11	NOT TO SCALE	TH	TH
			CHK.	CB

CLIENT
ENGAGE BUILDINGS PRODUCTS
FASTPLANK SYSTEMS

PROJECT
FASTPLANK SYSTEMS ALUMINUM
EXTERIOR WALL CLADDING

TITLE
ASSEMBLY DETAILS IN FLORIDA HIGH
VELOCITY HURRICANE ZONE (HVHZ)

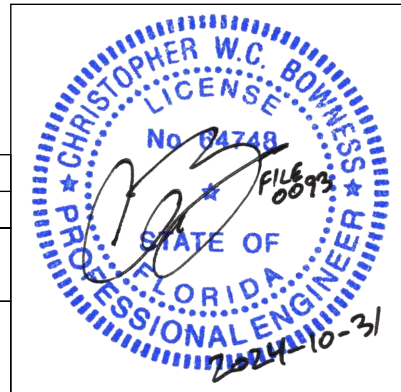

FASTPLANK SIDING

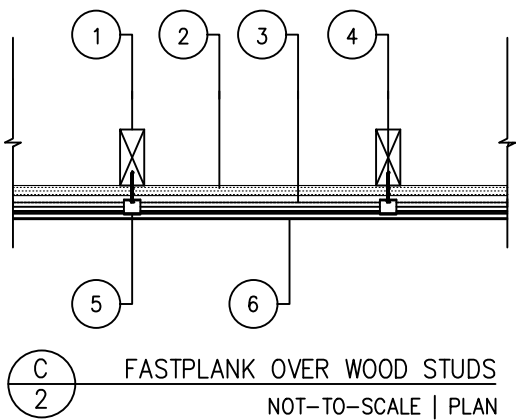
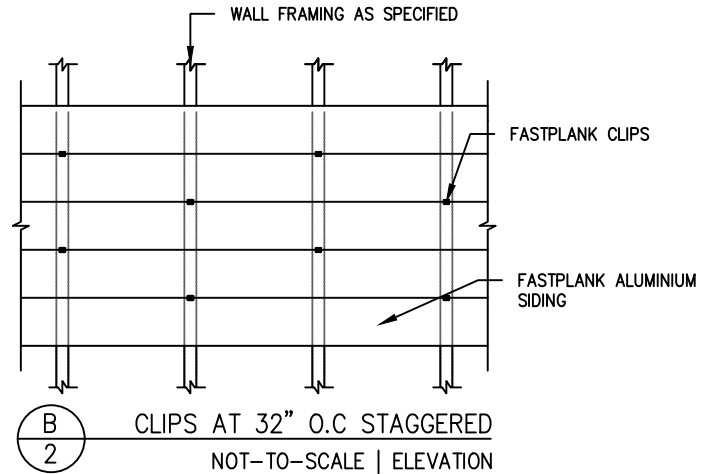
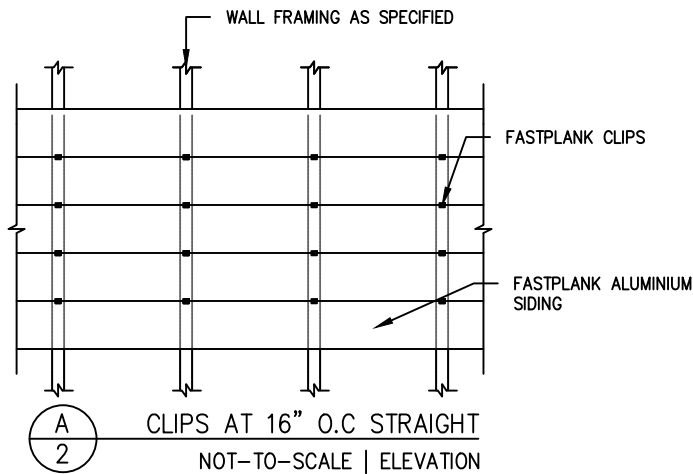

LIGHT-FRAMED STUD WALL INSTALLATION INTERIOR TO EXTERIOR	
1	WOOD STUD FRAMING PER WIND ASSEMBLY TABLE(S) ³
2	SHEATHING PER WIND ASSEMBLY TABLE(S) ³
3	WATER RESISTIVE BARRIER TO CODE
4	MIN. #10 1-½" WOOD SCREWS @ EACH CLIP
5	FASTPLANK CLIP PER WIND ASSEMBLY TABLE(S) ³
6	FASTPLANK SIDING

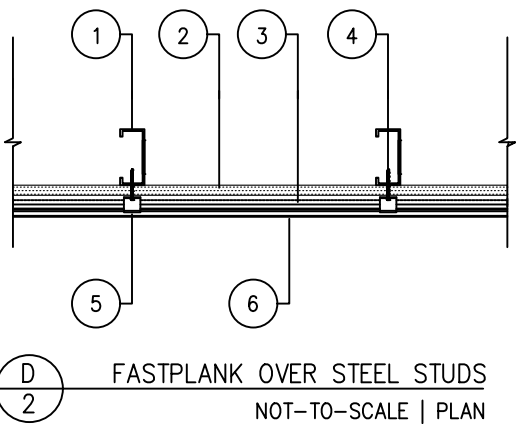

LIGHT-FRAMED STUD WALL INSTALLATION INTERIOR TO EXTERIOR	
1	STEEL STUDS PER WIND ASSEMBLY TABLE(S) ³
2	SHEATHING PER WIND ASSEMBLY TABLE(S) ³
3	WATER RESISTIVE BARRIER TO CODE BY OTHERS
4	MIN. #12 1-½" METAL SCREWS @ EACH CLIP
5	FASTPLANK CLIP PER WIND ASSEMBLY TABLE(S) ³
6	FASTPLANK SIDING

NOTE:

1. INTERIOR FINISH AND INSULATION TO CODE BY OTHERS, NOT SHOWN FOR CLARITY.
2. FLASHING AT ALL PENETRATIONS TO CODE BY OTHERS, NOT SHOWN FOR CLARITY.
3. ASSEMBLY TABLE(S) ARE FOUND ON PAGE 11 OF 11 OF THE DRAWING SET.



BOCA ENGINEERING
STRUCTURAL AND CIVIL ENGINEERS
#203-1001 CLOVERDALE AVE, VICTORIA BC
V8X 4C9 250-477-7777
INFO@BOCAENGINEERING.COM
WWW.BOCAENGINEERING.COM

DATE	OCTOBER 31, 2024		1	FOR PUBLICATION	CB
DRAWING NO.	PAGE NO.	SCALE	REV.	ISSUE	APP
0093-5965-SK2	2 OF 11	NOT TO SCALE			
		DES.	DRN.	CHK.	
		TH	TH	CB	

CLIENT
ENGAGE BUILDINGS PRODUCTS
FASTPLANK SYSTEMS

PROJECT
FASTPLANK SYSTEMS ALUMINUM
EXTERIOR WALL CLADDING

TITLE
ASSEMBLY DETAILS IN FLORIDA HIGH
VELOCITY HURRICANE ZONE (HVHZ)

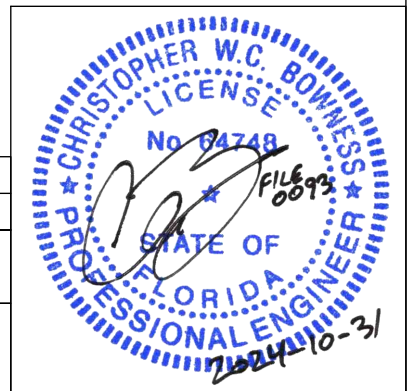

FASTPLANK SIDING AND SOFFIT

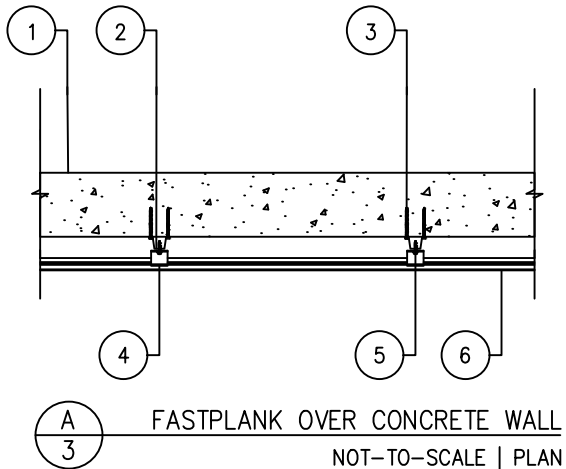

SOLID CONCRETE WALL INSTALLATION INTERIOR TO EXTERIOR	
1	MIN. 3000 PSI CONCRETE
2	(OPTIONAL) FURRING @ 16" O.C. PER WIND ASSEMBLY TABLE(S) ³
3	MIN. 5/16" Ø TAPCON ANCHORS PER WIND ASSEMBLY TABLE(S) ³ IF FURRING INSTALLED: TAPCON ANCHORS THRU FURRING INTO CONCRETE WALL. IF NO FURRING INSTALLED: TAPCON ANCHORS THRU CLIPS INTO CONCRETE WALL.
4	FASTPLANK CLIP PER WIND ASSEMBLY TABLE(S) ³
5	IF FURRING INSTALLED: MIN. #12 x 1 1/4" SCREWS INTO WOOD FURRING @ EACH CLIP MIN. #12 x 3/4" SCREWS INTO METAL FURRING @ EACH CLIP
6	FASTPLANK SIDING

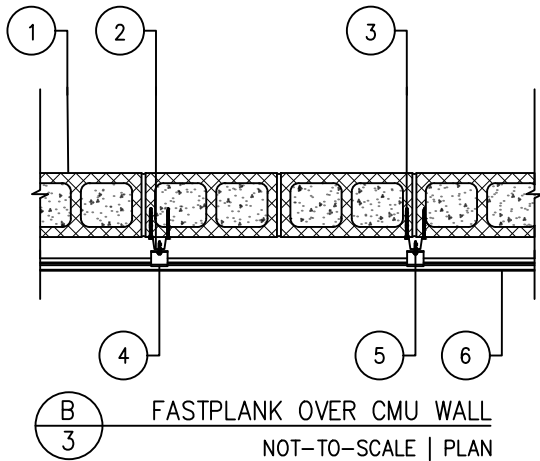

CONCRETE MASONRY UNIT (CMU) WALL INSTALLATION INTERIOR TO EXTERIOR	
1	HOLLOW <u>OR</u> GROUT-FILLED CMU WALL
2	(OPTIONAL) FURRING @ 16" O.C. PER WIND ASSEMBLY TABLE(S) ³
3	MIN. 5/16" Ø TAPCON ANCHORS PER WIND ASSEMBLY TABLE(S) ³ IF FURRING INSTALLED: TAPCON ANCHORS THRU FURRING INTO CMU WALL. IF NO FURRING INSTALLED: TAPCON ANCHORS THRU CLIPS INTO CMU WALL.
4	FASTPLANK CLIP PER WIND ASSEMBLY TABLE(S) ³
5	IF FURRING INSTALLED: MIN. #12 x 1 1/4" SCREWS INTO WOOD FURRING @ EACH CLIP MIN. #12 x 3/4" SCREWS INTO METAL FURRING @ EACH CLIP
6	FASTPLANK SIDING

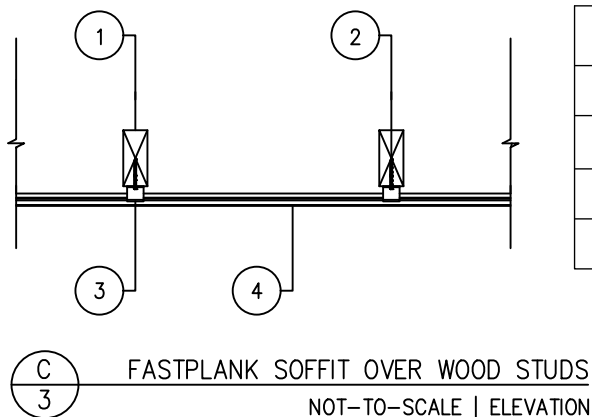

LIGHT-FRAMED STUD SOFFIT INTERIOR TO EXTERIOR	
1	WOOD STUD FRAMING PER WIND ASSEMBLY TABLE(S) ³
2	MIN. #10 1-1/2" WOOD SCREWS @ EACH CLIP
3	FASTPLANK CLIP PER WIND ASSEMBLY TABLE(S) ³
4	FASTPLANK SIDING AND/OR SOFFIT

NOTE:

1. INTERIOR FINISH AND INSULATION TO CODE BY OTHERS, NOT SHOWN FOR CLARITY.
2. FLASHING AT ALL PENETRATIONS TO CODE BY OTHERS, NOT SHOWN FOR CLARITY.
3. ASSEMBLY TABLE(S) ARE FOUND ON PAGE 11 OF 11 OF THE DRAWING SET.

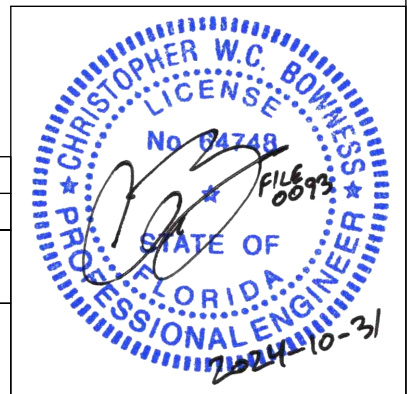

BOCA ENGINEERING
STRUCTURAL AND CIVIL ENGINEERS
#203-1001 CLOVERDALE AVE, VICTORIA BC
V8X 4C9 250-477-7777
INFO@BOCAENGINEERING.COM
WWW.BOCAENGINEERING.COM

DATE	OCTOBER 31, 2024	
DRAWING NO.	0093-5965-SK2	PAGE NO. 3 OF 11

1	FOR PUBLICATION	CB
REV.	ISSUE	APP
SCALE	DES.	DRN.
NOT TO SCALE	TH	TH
	CHK.	CB

CLIENT	PROJECT	TITLE
ENGAGE BUILDINGS PRODUCTS FASTPLANK SYSTEMS	FASTPLANK SYSTEMS ALUMINUM EXTERIOR WALL CLADDING	ASSEMBLY DETAILS IN FLORIDA HIGH VELOCITY HURRICANE ZONE (HVHZ)

FASTPLANK SIDING AND SOFFIT PROFILES

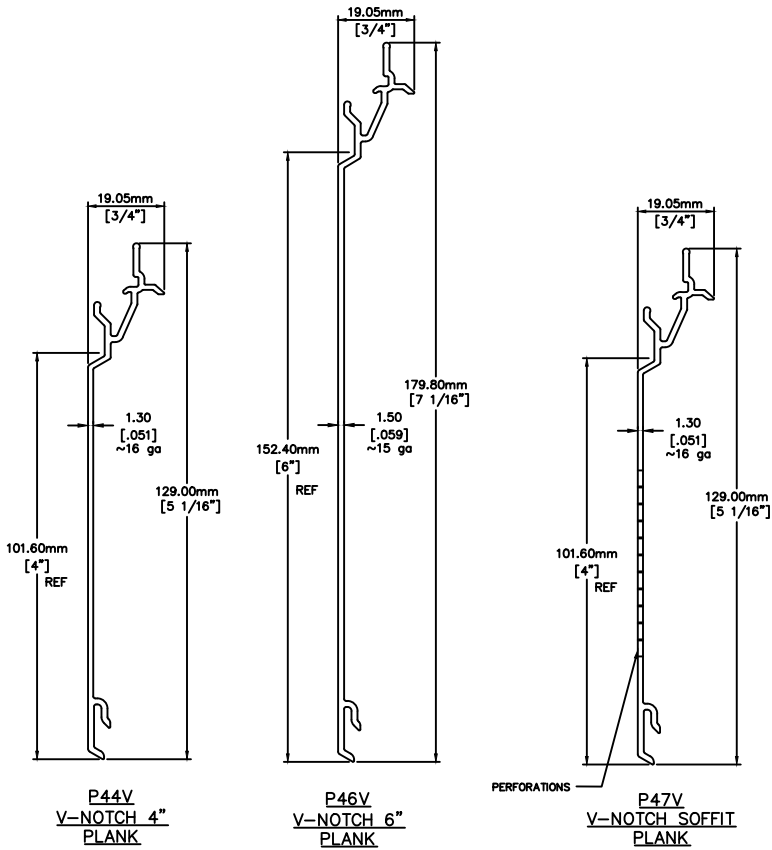

A
4 FASTPLANK V-NOTCH SIDING PLANKS
NOT-TO-SCALE

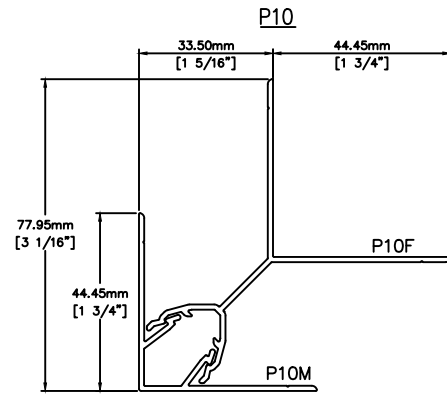

B
4 INSIDE/OUTSIDE CORNER
NOT-TO-SCALE

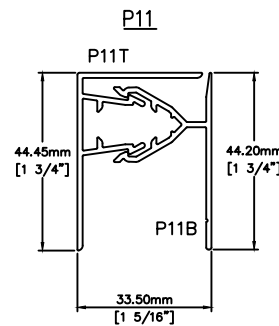

C
4 J-TRIM CLIP
NOT-TO-SCALE

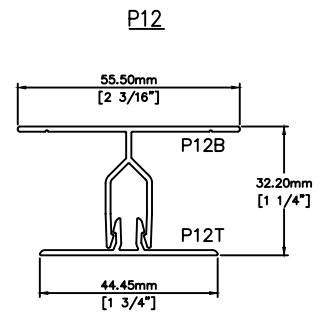

D
4 VERTICAL TRIM
NOT-TO-SCALE

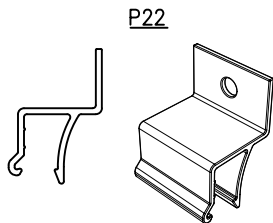

E
4 FASTPLANK CLIP
NOT-TO-SCALE

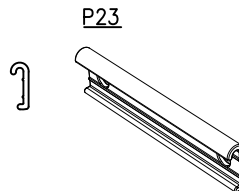

F
4 FASTPLANK CONNECTOR
NOT-TO-SCALE

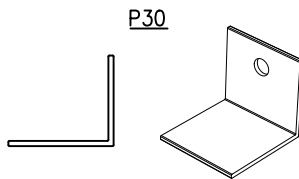

H
4 SPACER
NOT-TO-SCALE

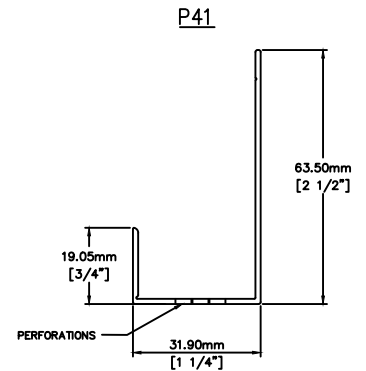

G
4 PERFORATED STARTER TRACK
NOT-TO-SCALE

BOCA ENGINEERING
STRUCTURAL AND CIVIL ENGINEERS
#203-1001 CLOVERDALE AVE, VICTORIA BC
V8X 4C9 250-477-7777
INFO@BOCAENGINEERING.COM
WWW.BOCAENGINEERING.COM

DATE
OCTOBER 31, 2024
DRAWING NO.
0093-5965-SK2
PAGE NO.
4 OF 11

1	FOR PUBLICATION	CB
REV.	ISSUE	APP
SCALE	DES.	DRN.
NOT TO SCALE	TH	TH
	CHK.	CB

CLIENT
ENGAGE BUILDINGS PRODUCTS
FASTPLANK SYSTEMS

PROJECT
FASTPLANK SYSTEMS ALUMINUM
EXTERIOR WALL CLADDING

TITLE
ASSEMBLY DETAILS IN FLORIDA HIGH
VELOCITY HURRICANE ZONE (HVHZ)

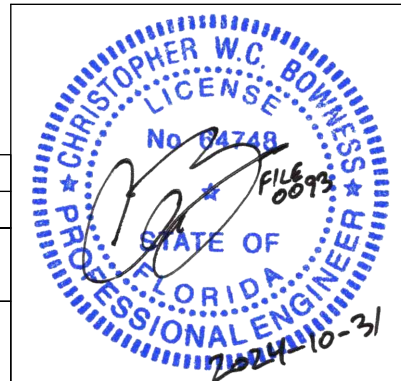

FASTPLANK SIDING OPENINGS AND END OF WALL DETAILS

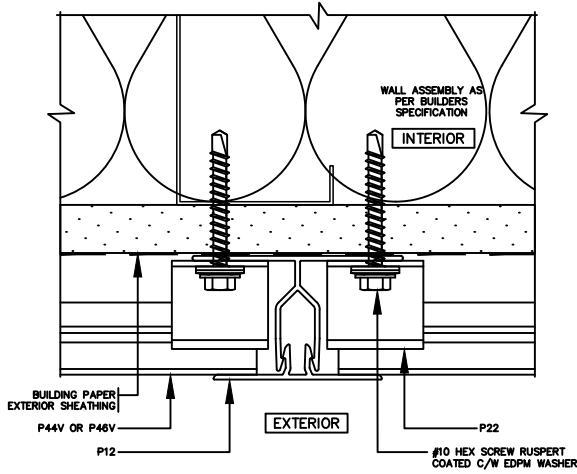

A
5 — 2-PC VERTICAL TRIM
NOT-TO-SCALE | PLAN

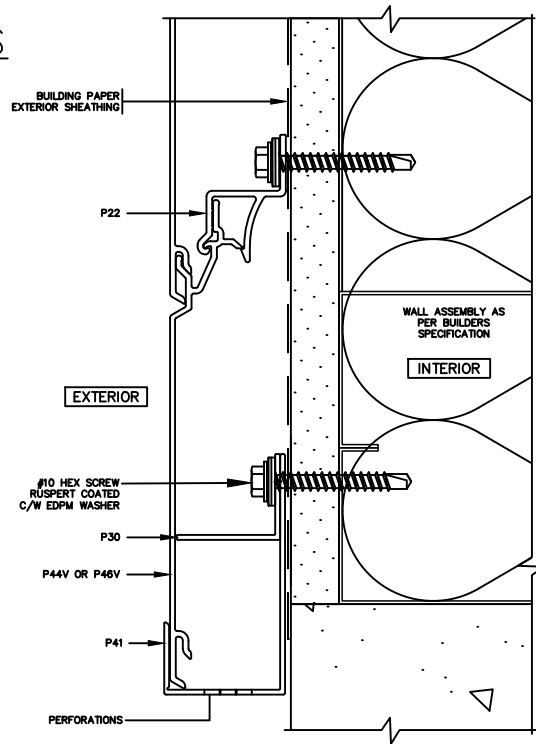

B
5 — PERFORATED STARTER J TRIM
NOT-TO-SCALE | ELEVATION

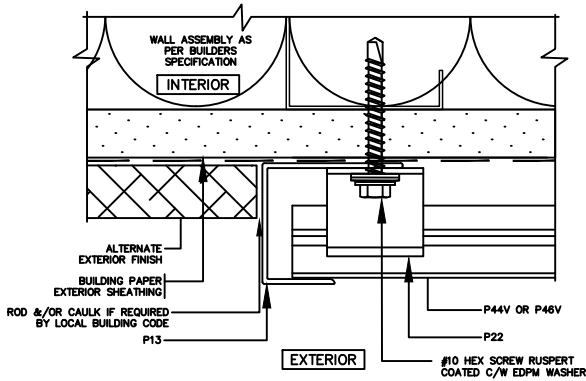

C
5 — GENERAL J VERTICAL TERMINATION
NOT-TO-SCALE | PLAN

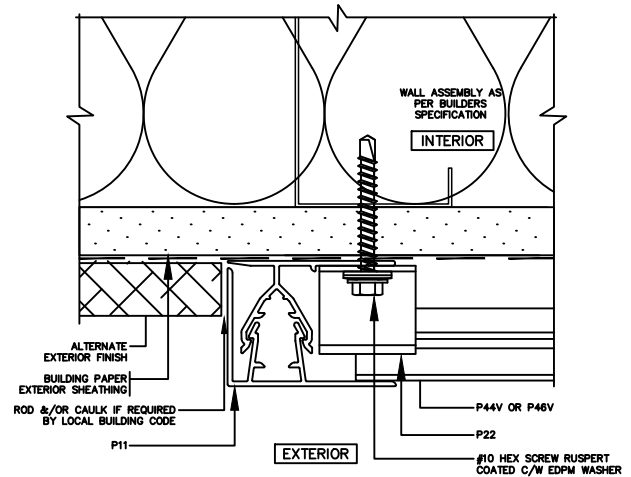

D
5 — 2-PC J VERTICAL TERMINATION
NOT-TO-SCALE | PLAN



BOCA ENGINEERING
STRUCTURAL AND CIVIL ENGINEERS
#203-1001 CLOVERDALE AVE, VICTORIA BC
V8X 4C9 250-477-7777
INFO@BOCAENGINEERING.COM
WWW.BOCAENGINEERING.COM

DATE	OCTOBER 31, 2024	
DRAWING NO.	PAGE NO.	
0093-5965-SK2	5 OF 11	

1	FOR PUBLICATION	CB
REV.	ISSUE	APP
SCALE	DES.	DRN.
NOT TO SCALE	TH	TH
	CHK.	CB

CLIENT
ENGAGE BUILDINGS PRODUCTS
FASTPLANK SYSTEMS

PROJECT
FASTPLANK SYSTEMS ALUMINUM
EXTERIOR WALL CLADDING

TITLE
ASSEMBLY DETAILS IN FLORIDA HIGH
VELOCITY HURRICANE ZONE (HVHZ)

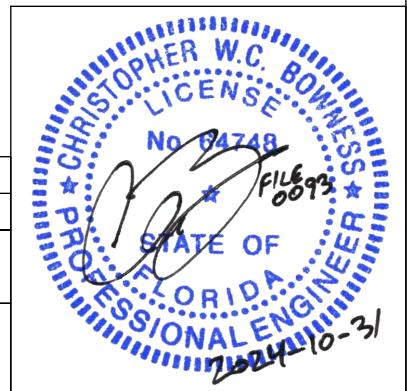

FASTPLANK SIDING OPENINGS AND END OF WALL DETAILS

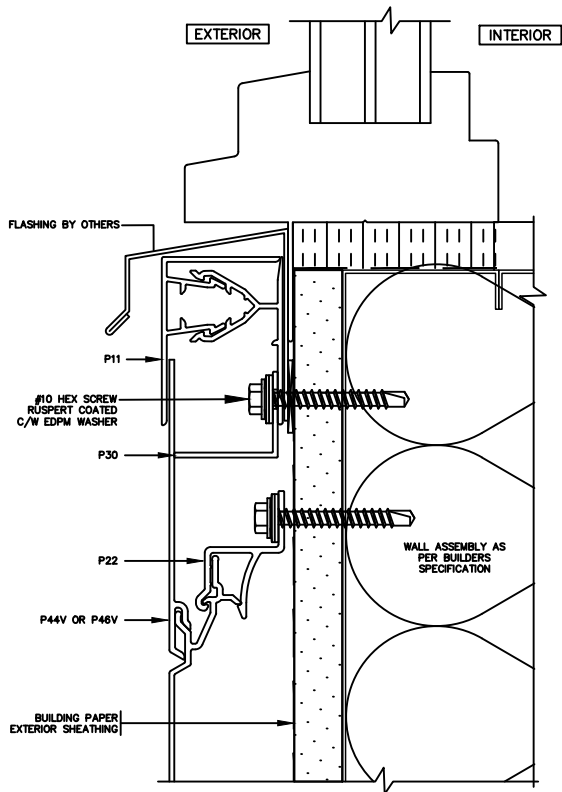

A
6 — 2-PC J TRIM WINDOW SILL
NOT-TO-SCALE | ELEVATION

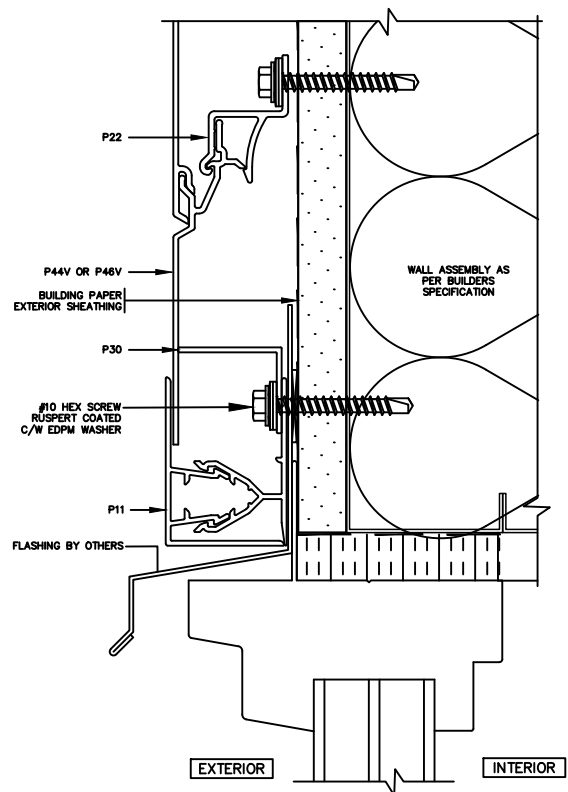

B
6 — 2-PC J TRIM WINDOW HEAD
NOT-TO-SCALE | ELEVATION

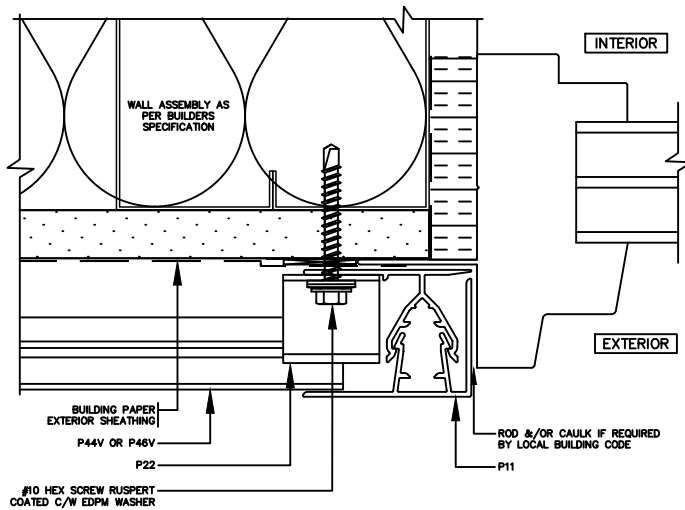

C
6 — 2-PC J TRIM WINDOW JAMB
NOT-TO-SCALE | PLAN



BOCA ENGINEERING
STRUCTURAL AND CIVIL ENGINEERS
#203-1001 CLOVERDALE AVE, VICTORIA BC
V8X 4C9 250-477-7777
INFO@BOCAENGINEERING.COM
WWW.BOCAENGINEERING.COM

DATE	OCTOBER 31, 2024		1	FOR PUBLICATION	CB
DRAWING NO.	PAGE NO.	SCALE	REV.	ISSUE	APP
0093-5965-SK2	6 OF 11	NOT TO SCALE			
			DES.	DRN.	CHK.
			TH	TH	CB

CLIENT	PROJECT	TITLE
ENGAGE BUILDINGS PRODUCTS FASTPLANK SYSTEMS	FASTPLANK SYSTEMS ALUMINUM EXTERIOR WALL CLADDING	ASSEMBLY DETAILS IN FLORIDA HIGH VELOCITY HURRICANE ZONE (HVHZ)

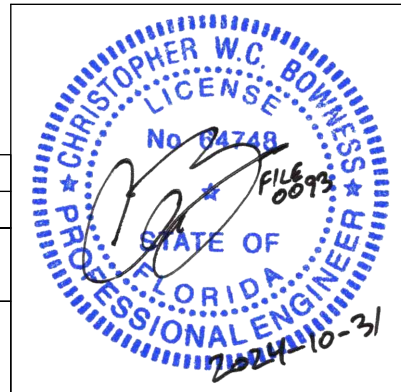

FASTPLANK SIDING OPENINGS AND END OF WALL DETAILS

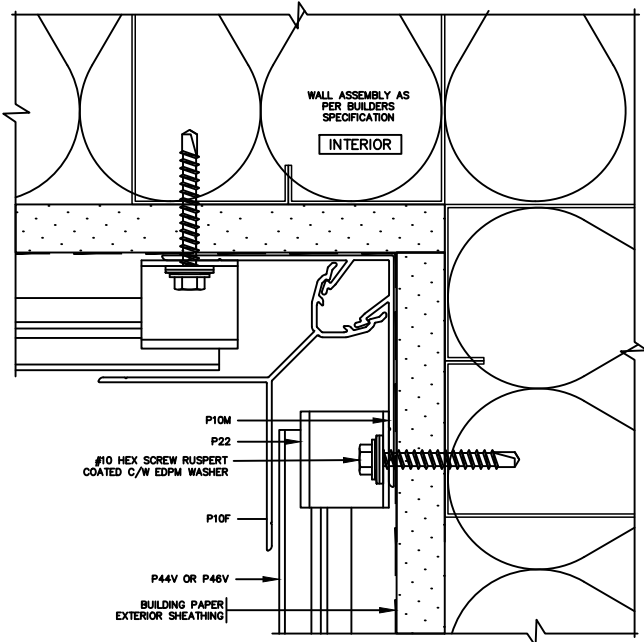

A
7

INSIDE CORNER TRIM DETAIL
NOT-TO-SCALE | PLAN

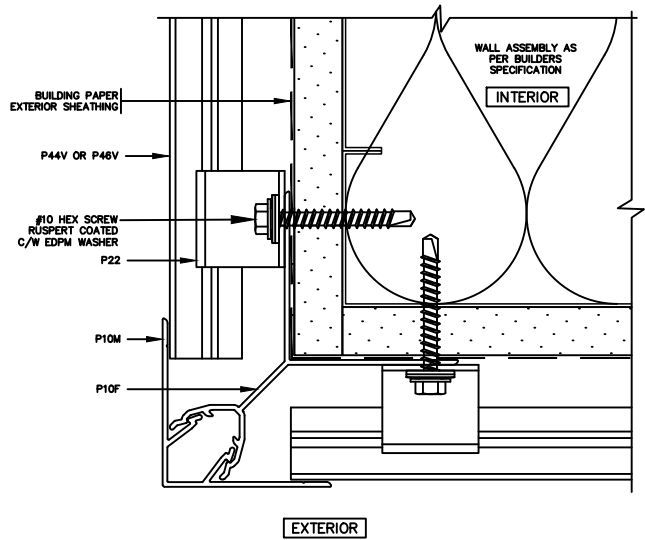

B
7

OUTSIDE CORNER TRIM DETAIL
NOT-TO-SCALE | PLAN

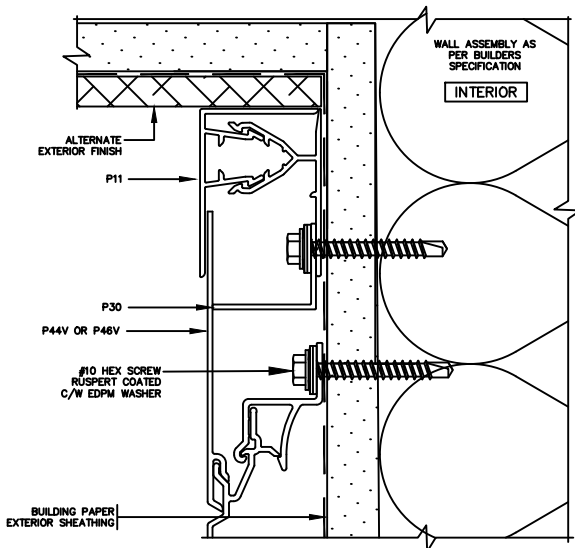

C
7

2-PC J SOFFIT TERMINATION
NOT-TO-SCALE | ELEVATION

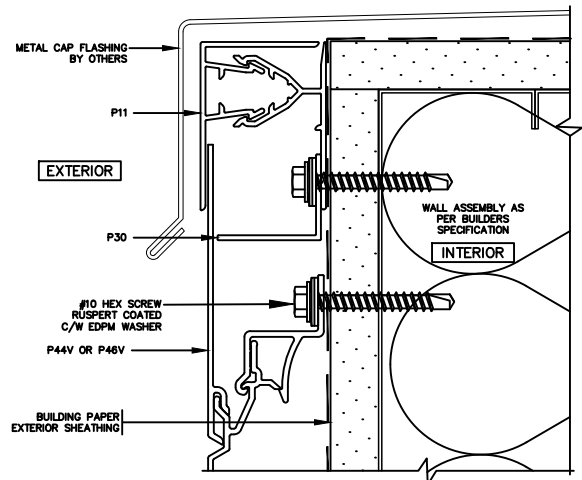

D
7

2-PC J PARAPET TERMINATION
NOT-TO-SCALE | ELEVATION



BOCA ENGINEERING
STRUCTURAL AND CIVIL ENGINEERS
#203-1001 CLOVERDALE AVE, VICTORIA BC
V8X 4C9 250-477-7777
INFO@BOCAENGINEERING.COM
WWW.BOCAENGINEERING.COM

DATE

OCTOBER 31, 2024

DRAWING NO.

0093-5965-SK2

PAGE NO.

7 OF 11

1

FOR PUBLICATION

CB

REV.

ISSUE

APP

SCALE

NOT TO SCALE

DES.

TH

DRN.

TH

CHK.

CB

CLIENT

ENGAGE BUILDINGS PRODUCTS
FASTPLANK SYSTEMS

PROJECT

FASTPLANK SYSTEMS ALUMINUM
EXTERIOR WALL CLADDING

TITLE

ASSEMBLY DETAILS IN FLORIDA HIGH
VELOCITY HURRICANE ZONE (HVHZ)

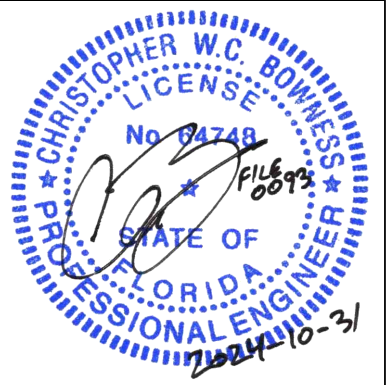

FASTPLANK SIDING AND SOFFIT END OF WALL WITH SOFFIT DETAILS

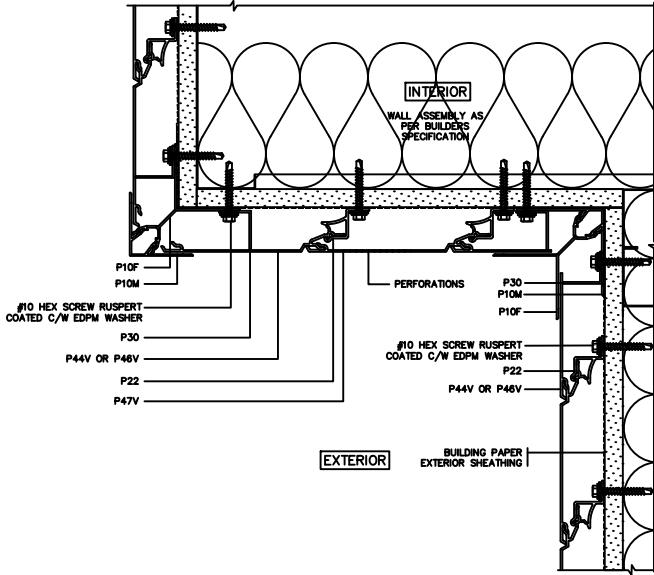

A
8 SOFFIT W/ INSIDE & OUTSIDE CORNER TRIM
NOT-TO-SCALE | ELEVATION

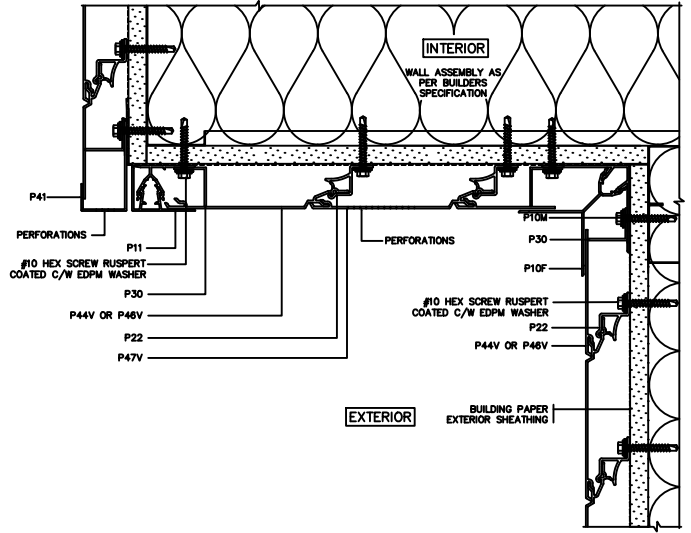

B
8 SOFFIT W/ INSIDE CORNER & 2-PIECE J TRIM
NOT-TO-SCALE | ELEVATION

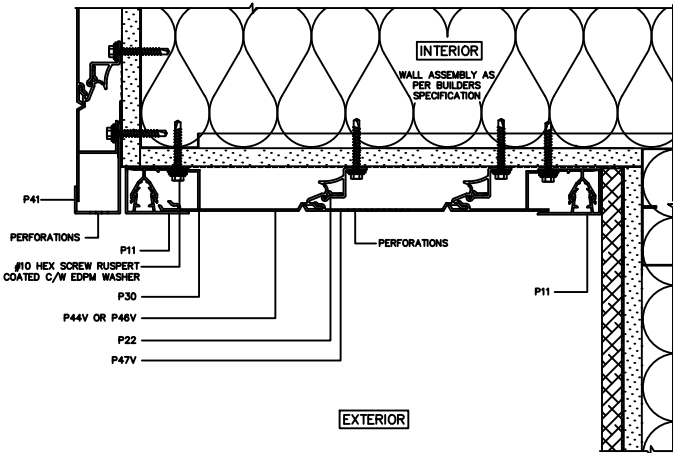

C
8 SOFFIT W/ 2-PIECE J TRIM DETAIL I
NOT-TO-SCALE | ELEVATION

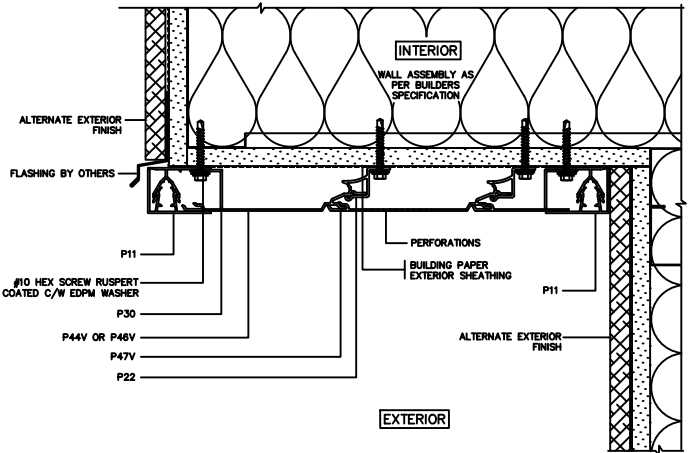

D
8 SOFFIT W/ 2-PIECE J TRIM DETAIL II
NOT-TO-SCALE | ELEVATION

BOCA ENGINEERING
STRUCTURAL AND CIVIL ENGINEERS
#203-1001 CLOVERDALE AVE, VICTORIA BC
V8X 4C9 250-477-7777
INFO@BOCAENGINEERING.COM
WWW.BOCAENGINEERING.COM

DATE
OCTOBER 31, 2024
DRAWING NO. 0093-5965-SK2
PAGE NO. 8 OF 11

1	FOR PUBLICATION	CB
REV.	ISSUE	APP
SCALE	DES.	DRN.
NOT TO SCALE	TH	TH
	CHK.	CB

CLIENT
ENGAGE BUILDINGS PRODUCTS
FASTPLANK SYSTEMS

PROJECT
FASTPLANK SYSTEMS ALUMINUM
EXTERIOR WALL CLADDING

TITLE
ASSEMBLY DETAILS IN FLORIDA HIGH
VELOCITY HURRICANE ZONE (HVHZ)

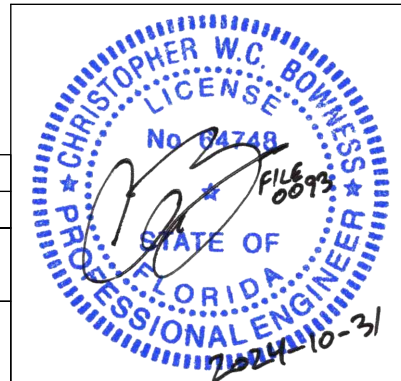

FASTPLANK SIDING AND SOFFIT

GENERAL NOTES

TESTING AND CODE COMPLIANCE

1. THE PRODUCT ASSEMBLY SHOWN IS DESIGNED TO COMPLY WITH THE 8TH EDITION (2023) FLORIDA BUILDING CODE (FBC) HVHZ AND HAS BEEN EVALUATED ACCORDING TO THE FOLLOWING TEST STANDARDS FOR WIND PRESSURE AND WIND-DRIVEN RAIN:
 - 1.1. TAS 100(A)-23
 - 1.2. TAS 202-94
 - 1.3. TAS 203-94
2. IMPACT RATED PER TAS 201 BY SPECIFYING MINIMUM 5/8" PLYWOOD SHEATHING PER MIAMI-DADE COUNTY CHECKLIST #0250 FOR METAL SIDING & SOFFIT - NOTE 3.
3. THE STRUCTURAL FRAMING AND SHEATHING SHALL BE DESIGNED AND ANCHORED TO PROVIDE LATERAL BRACING AND PROPERLY TRANSFER ALL LOADS TO THE STRUCTURE. FRAMING DESIGN AND INSTALLATION IS THE RESPONSIBILITY OF THE ENGINEER OR ARCHITECT OF RECORD FOR THE PROJECT OF INSTALLATION.
4. THESE DRAWINGS APPLY TO THE TESTING ASSEMBLY ONLY AND DO NOT IMPLY THAT THE SIGNATORY ENGINEER IS THE DESIGNER OF RECORD FOR ANY FUTURE CONSTRUCTION ON WHICH THEY ARE USED.
5. SOME NON-STRUCTURAL COMPONENTS NOT SHOWN AND DO NOT IMPACT STRENGTH FOR ATTACHMENT. TO BE INSTALLED PER CODE AND MAY INCLUDE: FLASHING, INTERIOR INSULATION, INTERIOR FINISH.

INSTALLATION

1. FOR COMPLETE INSTALLATION DETAILS SEE TECHNICAL PRODUCT DATA ON PRODUCT MANUFACTURER'S WEBSITE.
2. THE INSTALLATION DETAILS DESCRIBED ARE OF THE LABORATORY TESTED ASSEMBLY AND MAY NOT REFLECT ACTUAL CONDITIONS FOR A SPECIFIC SITE. IF SITE CONDITIONS DEVIATE FROM THE REQUIREMENTS DETAILED HEREIN, THE JOB ENGINEER OR ARCHITECT PREPARED SITE-SPECIFIC DOCUMENTS SHALL BE USED.

SHEATHING

1. WOOD-BASED STRUCTURAL SHEATHING:
 - 1.1. 5/8" PLYWOOD - US DOC PS1-09 OR PS2-10 U.N.O

FASTENERS

1. WOOD SCREWS TO CONFORM TO ASME B18.6.1.
2. METAL SCREWS TO CONFORM TO ASTM C1513.
3. ALL FASTENERS WITH CORROSION-RESISTANT GALVANIZED OR RUSPERT COATING.

FRAMING

1. METAL FRAMING MEMBERS MINIMUM 18 GAUGE U.N.O., 33ksi, COMPLIANCE WITH ANSI S100-16.
2. WOOD FRAMING MIN. 2x6 S.G. 0.42, COMPLIANCE WITH US DOC PS20-05.

ALUMINUM

1. ALUMINUM TO CONFORM WITH AA ADM 1

CONCRETE WALLS

1. ALL CONCRETE SHALL BE NORMAL WEIGHT CONTROLLED CONCRETE AND COMPLY WITH ACI 318 AND LOCAL STATE BUILDING CODE.
2. CONCRETE WALLS TO HAVE A MINIMUM 28-DAY COMPRESSIVE STRENGTH OF 3000 PSI.

CONCRETE MASONRY UNIT (CMU) WALLS

1. MASONRY WALL CONSTRUCTION SHALL CONFORM TO THE LOCAL STATE BUILDING CODE AND TMS 402/602.
2. HOLLOW-CORE CMU SHALL HAVE A MINIMUM 28-DAY COMPRESSIVE STRENGTH OF 1500 PSI.
3. GROUT TO CONFORM ASTM C476 AND HAVE A MINIMUM 28-DAY COMPRESSIVE STRENGTH OF 2000 PSI.

LEGEND AND SYMBOLS

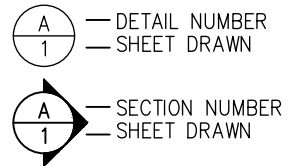

 BOCA ENGINEERING STRUCTURAL AND CIVIL ENGINEERS #203-1001 CLOVERDALE AVE, VICTORIA BC V8X 4C9 250-477-7777 INFO@BOCAENGINEERING.COM WWW.BOCAENGINEERING.COM	DATE	1	FOR PUBLICATION	CB		
	OCTOBER 31, 2024	REV.	ISSUE	APP		
	DRAWING NO.	PAGE NO.	SCALE	DES.	DRN.	CHK.
	0093-5965-SK2	9 OF 11	NOT TO SCALE	TH	TH	CB
CLIENT	PROJECT	TITLE				
ENGAGE BUILDINGS PRODUCTS FASTPLANK SYSTEMS	FASTPLANK SYSTEMS ALUMINUM EXTERIOR WALL CLADDING	ASSEMBLY DETAILS IN FLORIDA HIGH VELOCITY HURRICANE ZONE (HVHZ)				

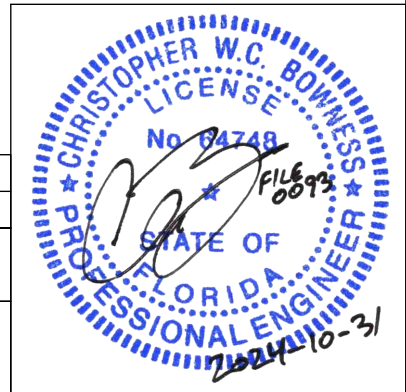

FASTPLANK SIDING AND SOFFIT
TABLE NOTES

WIND ASSEMBLY AND SPEED TABLE NOTES

1. THE SIDING HAS BEEN TESTED TO THE PUBLISHED ALLOWABLE PRESSURES AT THE RESPECTIVE BENDING LIMITATION OF L/180 FOR WALL HEIGHTS UP TO 10 FT. WHERE FRAMING AND SHEATHING DETAILS ARE PROVIDED IN THESE TABLES, THIS REPRESENTS ONLY THE MINIMUM TESTED OR CALCULATED MATERIALS FOR THE REQUIRED STRENGTH OF ATTACHMENT OF THE WALL CLADDING. PRIMARY STRUCTURAL BUILDING LOADS AND CAPACITY OF THE BUILDING FRAMING IS OUTSIDE THE SCOPE OF THIS TABLE AND MUST BE DESIGNED AND INSTALLED FOR THE APPLICABLE WIND, CLIMATE AND OCCUPANCY LOADS AS REQUIRED BY CODE FOR THE CONSTRUCTION PROJECT.
2. FURTHER ASSEMBLY DETAILS PER TABLES 1.1 AND 1.2 AND ADDITIONAL DETAILS IN THE ASSEMBLY DIAGRAMS OF THIS DRAWING TO BE FOLLOWED.
3. A STRAIGHT CONFIGURATION CONSISTS OF VERTICALLY ALIGNED CLIPS AT EACH PLANK WITH HORIZONTAL SPACING AS STATED.
4. A STAGGERED CONFIGURATION CONSISTS OF VERTICALLY ALIGNED CLIPS OF EVERY SECOND PLANK WITH THE CLIP STARTING LOCATIONS ALTERNATING BETWEEN THE FIRST AND SECOND PLANK ROWS TO CREATE A STAGGERED APPEARANCE.
5. WOOD FRAMING MINIMUM NOM 2X6 SPECIES SPF NO. 2 OR BETTER. MEMBERS MAY BE SUBSTITUTED WITH I) ANY LARGER SECTION DIMENSION OF THE SAME MATERIAL, AND/OR, II) ANY SPECIES/GRADE OF 0.42 SPECIFIC GRAVITY OR GREATER.
6. STEEL FRAMING MINIMUM DIMENSIONS 1-5/8 X 3-5/8, WITH MINIMUM YIELD STRENGTH OF 33 KSI AND 18 GA (43 MIL) THICKNESS. THE FRAMING MEMBERS MAY BE SUBSTITUTED WITH I) ANY LARGER SECTION DIMENSION OF THE SAME MATERIAL, AND/OR, II) ANY GREATER YIELD STRENGTH AND/OR GAUGE THICKNESS.
7. THE STRUCTURAL FRAMING AND SHEATHING SHALL BE DESIGNED AND ANCHORED TO PROVIDE LATERAL BRACING AND PROPERLY TRANSFER ALL LOADS TO THE STRUCTURE. FRAMING DESIGN AND INSTALLATION IS THE RESPONSIBILITY OF THE ENGINEER OR ARCHITECT OF RECORD FOR THE PROJECT OF INSTALLATION.
8. FASTENERS SUPPLIED WITH FASTPLANK SIDING MUST BE USED.
9. PLYWOOD SHEATHING: MIN. 19/32, 0.42 SG, 4-PLY EXPOSURE 1, COMPLYING WITH NIST DOC PS 2. PLYWOOD SHEATHING MAY BE SUBSTITUTED WITH THICKER PROFILE OF UP TO NOMINAL 1-INCH, AND ANY SPECIFIC GRAVITY GREATER THAN 0.42.
10. OSB SHEATHING: N/A.
11. ALLOWABLE PRESSURE (PSF) (ASD) REPRESENTS THE DESIGN PRESSURE, AS DEFINED IN TAS 202, IN WHICH IT WAS TESTED TO A TEST LOAD OF 1.5 TIMES THE DESIGN PRESSURE.
12. ALLOWABLE WIND PRESSURE (ASD), AS DEFINED IN ASCE 7-22 2.4.1 AS 0.6W. TO CONVERT TO FACTORED DESIGN RESISTANCE PRESSURE (PSF) (LRFD), MULTIPLY ALLOWABLE PRESSURE (PSF) (ASD) BY 1.67.
13. ALLOWABLE PRESSURE (PSF) (ASD) FOR ASSEMBLIES IN HVHZ DETERMINED IN ACCORDANCE WITH TAS 202 AND 203.
14. PER 2023 FBC 1620.3, ALL HVHZ BUILDINGS AND STRUCTURES SHALL BE CONSIDERED TO BE IN EXPOSURE CATEGORY C, UNLESS CATEGORY D APPLIES, AS DEFINED IN SECTION 26.7 OF ASCE 7.
15. 1-5/8" x 5-1/2" 50 ksi 16-GAUGE STEEL STUD @ 16", ON CENTRE CONFIGURATION ONLY APPLICABLE FOR WALL HEIGHTS UP TO 9 FT.



BOCA ENGINEERING
STRUCTURAL AND CIVIL ENGINEERS
#203-1001 CLOVERDALE AVE, VICTORIA BC
V8X 4C9 250-477-7777
INFO@BOCAENGINEERING.COM
WWW.BOCAENGINEERING.COM

DATE OCTOBER 31, 2024		1	FOR PUBLICATION		CB	
DRAWING NO. 0093-5965-SK2		PAGE NO. 10 OF 11	REV.	ISSUE	APP	
CLIENT ENGAGE BUILDINGS PRODUCTS FASTPLANK SYSTEMS		PROJECT FASTPLANK SYSTEMS ALUMINUM EXTERIOR WALL CLADDING	SCALE NOT TO SCALE	DES. TH	DRN. TH	CHK. CB
		TITLE ASSEMBLY DETAILS IN FLORIDA HIGH VELOCITY HURRICANE ZONE (HVHZ)				

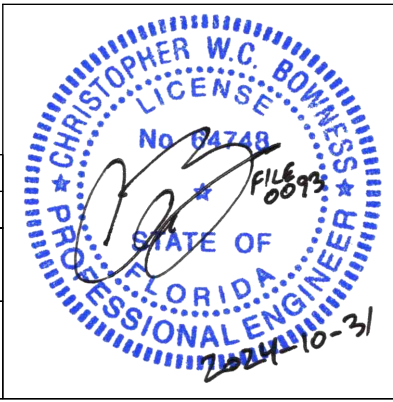

FASTPLANK SIDING AND SOFFIT WIND ASSEMBLY AND SPEED TABLE(S)

Table 1.1: Wind Assembly Details with FastPlank P44V and P46V planks – 2023 FBC
Height Limit of 10 ft, Bending Deflection Limit of L/180^{1,13,14}

Assembly Number ²	Configuration ^{3,4}	Fastener Substrate	Min. Framing ^{5,6,7}	Fastener ⁸	Min. Sheathing ^{9,10}	Allowable Pressure (psf) (ASD) ^{11,12}
1	Clips @ 32" O.C. staggered	Stud	2x6 SPF No. 2 wood studs @ 16" o.c.	#10 x 1-3/4 in. screw	5/8" Plywood	70
2	Clips @ 16" O.C. straight	Stud	2x6 SPF No. 2 wood studs @ 16" o.c.	#10 - 1-1/2" screw	5/8" Plywood	140
3	Clips @ 32" O.C. staggered	Stud	1-5/8 x 3-5/8 33 ksi 18 ga. steel stud @ 16" o.c.	#12 - 1-1/2" screw	5/8" Plywood	70
4 ¹⁵	Clips @ 16" O.C. straight	Stud	1-5/8 x 5-1/2 50 ksi 16 ga. steel stud @ 16" o.c. *See note ¹⁵	#12 - 1-1/2" screw	5/8" Plywood	140
5	Clips @ 16" O.C. Straight	Furring into Concrete/CMU	Vertical wood furring @ 16" o.c.: 2x2 SPF No.2 wood or better;	#12 - 1-1/2" screw to wood furring; 5/16" Buildex Tapcon @ 16" o.c. to substrate; min. 1-3/4" embed	N/A	140
6	Clips @ 16" O.C. Straight	Furring into Concrete/CMU	Vertical 7/8"x1-1/4" 20ga 33ksi steel hat Channel; <u>OR</u> Vertical Z 1-3/4"x1-3/4"x3/16" 6005 or 6031 aluminum alloy z-girt	#12 - 3/4" screw to metal furring; 5/16" Buildex Tapcon anchors @ 16" o.c. to substrate; min. 1-3/4" embed	N/A	140
7	Clips @ 16" O.C. Straight	CMU	Hollow <u>or</u> Grout-filled Concrete Masonry Unit (CMU)	5/16" Tapcon anchors @ 16" o.c.; 1-3/4" embed; 4" edge distance	N/A	140
8	Clips @ 16" O.C. Straight	Concrete	3000 psi concrete	5/16" Tapcon anchors @ 16" o.c.; 1-3/4" embed; 2-3/16" edge distance	N/A	140

Table 1.2: Wind Assembly Details with FastPlank Soffit planks – 2023 FBC^{1,13,14}

Assembly Number ²	Configuration ^{3,4}	Fastener Substrate	Min. Framing ^{5,6,7}	Fastener ⁸	Min. Sheathing ^{9,10}	Allowable Pressure (psf) (ASD) ^{11,12}
9	Clips @ 24" O.C. straight	Joist	2x6 SPF No. 2 lumber @ 24" o.c.	#10 - 1-1/2" screw	N/A	95

*TABLE NOTES ON PREVIOUS SHEET(S)



BOCA ENGINEERING
STRUCTURAL AND CIVIL ENGINEERS
#203-1001 CLOVERDALE AVE, VICTORIA BC
V8X 4C9 250-477-7777
INFO@BOCAENGINEERING.COM
WWW.BOCAENGINEERING.COM

DATE	OCTOBER 31, 2024		1	FOR PUBLICATION	CB
DRAWING NO.	PAGE NO.	SCALE	DES.	DRN.	CHK.
0093-5965-SK2	11 OF 11	NOT TO SCALE	TH	TH	CB
CLIENT	PROJECT	TITLE			
ENGAGE BUILDINGS PRODUCTS FASTPLANK SYSTEMS	FASTPLANK SYSTEMS ALUMINUM EXTERIOR WALL CLADDING	ASSEMBLY DETAILS IN FLORIDA HIGH VELOCITY HURRICANE ZONE (HVHZ)			

