



ENGINEERING EVALUATION REPORT

Issue Date	2023-12-06
Expiry Date	2024-12-31
Report Number	0093-10-2-5913
Client Name	FastPlank Systems Inc.
Address	101-4441 76th Ave SE, Calgary, AB T2C 2G8

Subject

FastPlank Systems aluminum siding planks. Fire/Flammability Testing Results.

Product Description

Fastplank Systems are aluminum siding planks with fastening clips and trim accessories, serving as an exterior wall covering. Planks are extruded 3/64" thick aluminum with a V-Notch™ profile, available in widths of 4" or 6" and in 16' or 32' lengths. The plank exterior surface is typically finished with a powder-coat paint in a variety of colors.

Evaluation

Testing of the siding planks has been conducted in accordance with the referenced test standards at Intertek - Coquitlam, BC location. Intertek is an independent testing laboratory accredited by the International Accreditation Service (IAS).

Standard	Property	Sample Description	Test Results
ASTM E84-20	Surface Burning Characteristics	V-Notch plank, finished (with powder-coat paint applied)	¹ Flame Spread Index: 5 ¹ Smoke Developed Index: 100
ASTM E136-19a	Combustion	V-Notch plank, unfinished (no paint applied)	Met requirements of ASTM E136 for non-combustible classification
SFM 12-7A-1-(2019)	Exterior Wildfire Exposure	See Assembly details drawing 0093-SK2 attached to this report	Met conditions of acceptance

1. Average of two samples tested.

ASTM E84 and E136 are cited testing standards in 2021 International Building Code (IBC), Ch 35 *Referenced Standards*. SFM 12-7A-1 is a cited testing standard in 2022 California Building Code (CBC), Ch 35 *Referenced Standards*.

Source Documents

The published versions of the following sources, current on the date of this evaluation, were used as reference material to support the conclusions made:

1. ASTM E84-20 results: Intertek report 104572653COQ-004, dated 2021-03-18.
2. ASTM E136-19a results: Intertek report 104572653COQ-004, dated 2021-04-27.
3. SFM 12-7A-1-(2019) results: Intertek report 105008863COQ-004R2, dated 2022-06-22.



Signed

This report has been prepared and reviewed on behalf of BOCA by:

Chris Bowness, P.Eng., P.E.

2023-12-06

Date



EVALUATION REPORT TERMS:

1. This report is a general evaluation of the building code sections and/or standards requirements as identified and applies only to the samples that were evaluated. It does not imply any endorsement or warranty, nor that the signatory Engineer is the Designer of Record of any construction project for which the information is used.
2. This Evaluation Report expires Dec. 31, 2024, open to renewal. Up to the renewal date, the report is valid until such time as the named product(s) changes, the Quality Assurance Agency changes, or provisions of the Code that relate to the product change.

CERTIFICATION OF INDEPENDENCE:

1. Boca Engineering Co., its employees and shareholders, do not have, nor do they intend to or will acquire, a financial interest in any company manufacturing or distributing products that they evaluate.
2. Boca Engineering Co. is not owned, operated or controlled by any company manufacturing or distributing products that they evaluate.

Attachments

Assembly Diagrams Attachment begins next page.

-END-

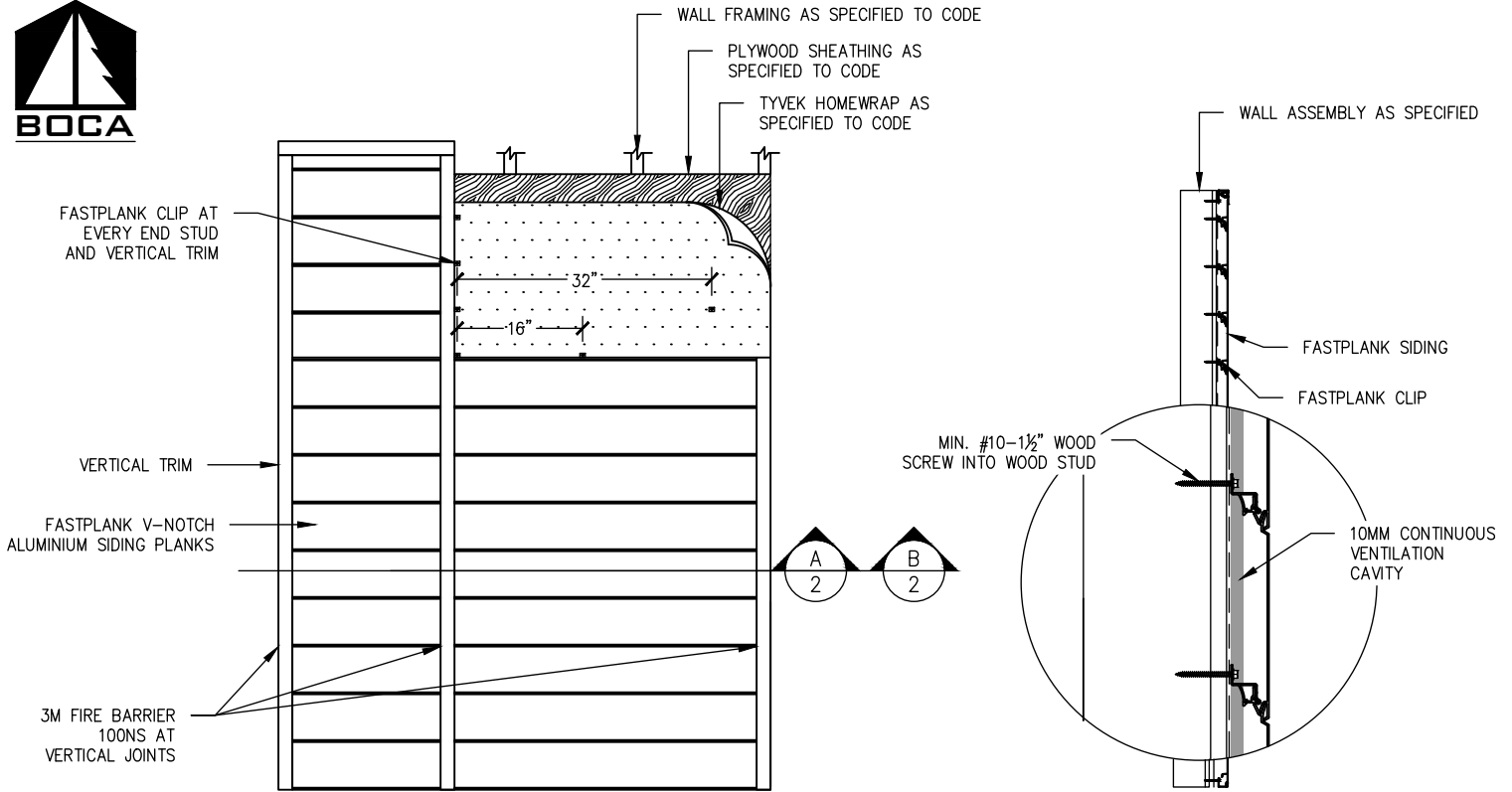

A
1 FASTPLANK INSTALLATION INTO WOOD STUDS
ELEVATION NOT-TO-SCALE

B
1 FASTPLANK INSTALLATION INTO WOOD STUDS
SECTION NOT-TO-SCALE

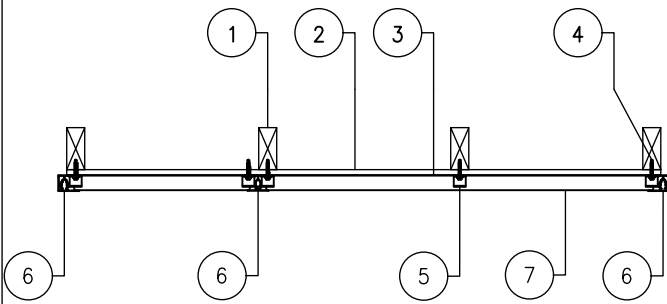

C
1 FASTPLANK P46V TEST ASSEMBLY
PLAN NOT-TO-SCALE

FASTPLANK FIRE TESTED ASSEMBLY INSTALLATION INTERIOR TO EXTERIOR	
1	2x4 SPF No.2 WOOD STUDS @ 16" O.C.
2	5/8" PLYWOOD SHEATHING.
3	TYVEK HOUSEWRAP
4	#10-16, 1½" LONG WOOD SCREWS @ EACH CLIP
5	FASTPLANK CLIP @ 32" O.C HORIZONTALLY AND @ EVERY END STUD AND VERTICAL TRIM
6	3M 100NS FIRE BARRIER CAULKING AT ALL VERTICAL JOINTS
7	FASTPLANK P46V* V-NOTCH SIDING (*P44V ACCEPTABLE SUBSTITUTE)

NOTE:

1. INTERIOR FINISH AND INSULATION NOT SHOWN. FOR CLARITY.
2. FLASHING: (NOT SHOWN) FLASHING PER 2019 CBC SECTION 1404.4 AT ALL PENETRATIONS.

COPYRIGHT © 2023 RESERVED. THESE PLANS AND DESIGNS ARE AT ALL TIMES THE PROPERTY OF BOCA ENGINEERING TO BE USED FOR THE PROJECT SHOWN. WRITTEN CONSENT IS REQUIRED FROM THE ENGINEER BEFORE ANY REPRODUCTION.

TITLE FASTPLANK SYSTEMS ASSEMBLY DETAILS FOR USE IN SFM STANDARD 12-7A-1	CLIENT ENGAGE BUILDING PRODUCTS FASTPLANK SYSTEMS	PROJECT FASTPLANK SYSTEMS 4441 76 AVE SE #101 CALGARY, AB T2C 2G8
DATE DECEMBER 06, 2023	REV. 1	FOR PUBLICATION CB
DRAWING NO. 5913-SK1	SHEET NO. 1 OF 2	ISSUE APP
BOCA ENGINEERING CO. SPAR STRUCTURAL & CIVIL CONSULTANTS	SCALE NOT TO SCALE	DES. CB DRN. NN CHK. CB

DRAWING FOR ENGINEERING
EVALUATION REPORT – NOT
FOR USE AS CONSTRUCTION
DESIGN DOCUMENTS

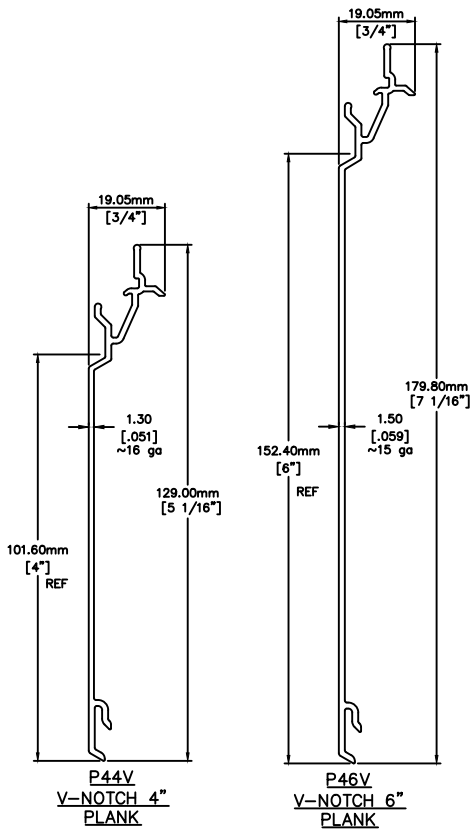
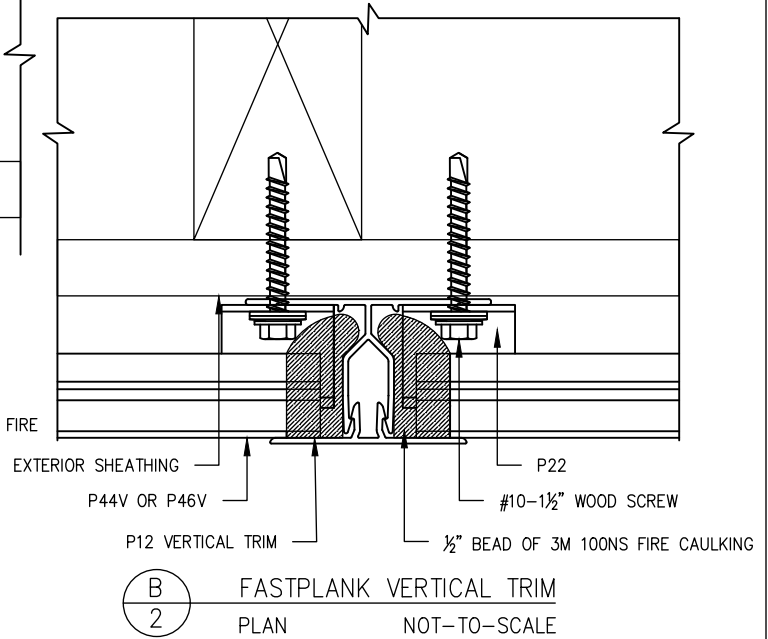
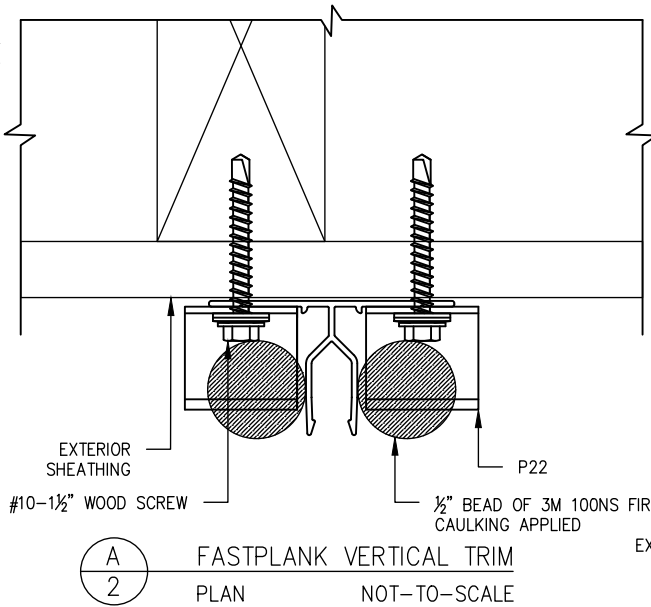

TESTING AND CODE COMPLIANCE

1. THE SIDING PRODUCT ASSEMBLY SHOWN IS DESIGNED TO COMPLY WITH SECTION 707A.3 OF THE 2019 CALIFORNIA BUILDING CODE (CBC) AND HAS BEEN EVALUATED ACCORDING TO SFM STANDARD 12-7A-1 – MATERIALS AND CONSTRUCTION METHODS FOR EXTERIOR WILDFIRE EXPOSURE – EXTERIOR WALL SIDING AND SHEATHING. THE ASSEMBLY HAS SUCCESSFULLY MET THE CONDITIONS OF THE AFOREMENTIONED TEST STANDARD.
2. THE STRUCTURAL FRAMING AND SHEATHING SHALL BE DESIGNED AND ANCHORED TO PROVIDE LATERAL BRACING AND PROPERLY TRANSFER ALL LOADS TO THE STRUCTURE. FRAMING DESIGN AND INSTALLATION IS THE RESPONSIBILITY OF THE ENGINEER OR ARCHITECT OF RECORD FOR THE PROJECT OF INSTALLATION.
3. THESE DRAWINGS APPLY TO THE TESTING ASSEMBLY ONLY AND DO NOT IMPLY THAT THE SIGNATORY ENGINEER IS THE DESIGNER OF RECORD FOR ANY FUTURE CONSTRUCTION ON WHICH THEY ARE USED.
4. SOME NON-STRUCTURAL COMPONENTS NOT SHOWN AND DO NOT IMPACT EXTERIOR FIRE RESISTANCE. TO BE INSTALLED PER CODE AND MAY INCLUDE: FLASHING, INTERIOR INSULATION, INTERIOR FINISH.

INSTALLATION

THE INSTALLATION DETAILS DESCRIBED ARE OF THE LABORATORY TESTED ASSEMBLY AND MAY NOT REFLECT ACTUAL CONDITIONS FOR A SPECIFIC SITE. IF SITE CONDITIONS DEVIATE FROM THE REQUIREMENTS DETAILED HEREIN, THE LICENSED ENGINEER OR ARCHITECT PREPARED SITE-SPECIFIC DOCUMENTS SHALL BE USED.

SHEATHING

1. WOOD-BASED STRUCTURAL SHEATHING TO CONFORM TO US DOC PS1-09 OR PS2-10 U.N.O.

FASTENERS

1. WOOD SCREWS TO CONFORM TO ASME B18.6.1 U.N.O

FRAMING

1. WOOD FRAMING MIN. 2x4 S.G. 0.42, COMPLIANCE WITH US DOC PS20-05

ALUMINUM

1. ALUMINUM TO CONFORM TO AAMA1402-09, GRADE 6063-T6

A
3
FASTPLANK V-NOTCH SIDING PLANKS
NOT-TO-SCALE

COPYRIGHT © 2023 RESERVED. THESE PLANS AND DESIGNS ARE AT ALL TIMES THE PROPERTY OF BOCA ENGINEERING TO BE USED FOR THE PROJECT SHOWN. WRITTEN CONSENT IS REQUIRED FROM THE ENGINEER BEFORE ANY REPRODUCTION.

BOCA ENGINEERING CO. SPAR STRUCTURAL & CIVIL CONSULTANTS	TITLE FASTPLANK SYSTEMS ASSEMBLY DETAILS FOR USE IN SFM STANDARD 12-7A-1		CLIENT ENGAGE BUILDING PRODUCTS FASTPLANK SYSTEMS		PROJECT FASTPLANK SYSTEMS 4441 76 AVE SE #101 CALGARY, AB T2C 2G8			
	DATE DECEMBER 06, 2023		REV. 1		FOR PUBLICATION CB		DRAWING FOR ENGINEERING EVALUATION REPORT – NOT FOR USE AS CONSTRUCTION DESIGN DOCUMENTS	
	DRAWING NO. 5913-SK1		SHEET NO. 2 OF 2		SCALE NOT TO SCALE			DES. CB