



**NATIONAL AND PROVINCIAL CANADIAN CODES
ENGINEERING EVALUATION REPORT**

Issue Date	2025-03-28
Expiry Date	2025-12-31
Report Number	0093-15-3-6034
Client Name	FastPlank Inc.
Address	101-4441 76th Ave SE, Calgary, AB T2C 2G8

Subject

FastPlank Systems aluminum exterior wall siding planks and soffit coverings.

Evaluation Scope

This report is provided to assist registered design professionals and building officials in Canada with determining compliance to the performance objectives in the named building codes.

The material(s) and system(s) described herein have been evaluated to:

- 2020 National Building Code of Canada (NBCC);**
- 2024 British Columbia Building Code (BCBC);**
- 2024 Ontario Building Code [Last Revision: May 2024] (OBC);**
- 2023 National Building Code – Alberta Edition (NBC (AE));**

Division A, Sections 1.2.1.1.(1)(a) for compliance with the objectives and functional statements attributed to the applicable acceptable solutions in Division B, for buildings classified under Part 3/4/5 and Part 9 construction.

CSI DIVISION: 07 00 00 THERMAL AND MOISTURE PROTECTION

SUBDIVISION: 07 46 16 Aluminum Siding, 07 42 93 Soffit Panels

CODE SECTIONS AND STANDARDS: 2020 NBCC

Div. B Section	Description	Referenced Standard or Div. B Section ¹	Year
Part 3/4/5			
1.4.1.2.(1)²	Determination of Noncombustibility	CAN/ULC S114	2018
3.1.4.8(1)(a)	Exterior Cladding, Combustible Construction	-	-
3.1.5.1	Noncombustible Materials	Div A 1.4.1.2	-
3.1.5.2	Minor Combustible Components	-	-
3.1.7.1	Determination of (Fire-Resistance) Ratings	CAN/ULC-S101	2014
3.1.12.1(1)	Determination of (Flame-Spread and Smoke Developed Classification) Ratings	CAN/ULC-S102	2010
3.2.3.16.1 (a)	Protection of Soffits	Div A 1.4.1.2.(1)	-
4.1.3.5	Deflection, Limit States Design	-	-
4.1.7.1(5)(a)	Specified Wind Load	4.1.7.3	-
4.3.5.1	Design Basis for Aluminium	CAN/CSA S157, S157.1	2017
5.1.4.1	Resistance to Structural and Environmental Loads	5.2.1, 5.2.2, 4.1.3.5	-
5.1.4.2	Resistance to Deterioration	-	-
5.2.1.3(3)	Environmental (Wind) Load and Transfer Calculations	4.1.7	-



5.6.1.1	Required Protection from Precipitation	-	-
5.6.2.1	Sealing and Drainage	-	-
5.9.1.1(1)(b)	Compliance with Applicable Standards	CGSB 93.1, 93.2	1985, 1991
5.9.3.5	Water Penetration	ASTM E331	2000
A-5.9.3.2(1)	Structural and Environmental Loads	ASTM E330	2014
Part 9			
9.4.1.1(1)(c)(ii)	General, Structural Design Requirements and Application Limitations	Part 4	-
9.10.3.1(1)(a)	Fire-Resistance and Fire-Protection Ratings	Part 3	-
9.10.3.2(1)	Flame-Spread Ratings	Part 3	-
9.10.6.1	Combustible Elements in Noncombustible Construction, Construction Types	3.1.5	-
9.10.12.4 (3)(a)	Protection of Soffits	Div A 1.4.1.2.(1).	-
9.27.1.1(1)	General, Application, Cladding	9.27.2 – 9.27.12, Part 5	-
9.27.2.2(1)(a)	Minimum Protection from Precipitation Ingress	-	-
9.27.11.1	Material Standards, Metal	CGSB 93.1, 93.2	1985, 1991

- Only the applicable reference standards and code sections cited in the main body text are listed. (-) indicates that the main body text covers the full explanation of the objective.
- Definition appears in Div A.

COMPLIANCE STATEMENT:

It is the opinion of Boca Engineering Co. that FastPlank Systems aluminum exterior wall cladding when installed as described in this report, has demonstrated compliance with the listed sections of the named building codes. Design and performance information can be found in the Product Evaluation section this report.

This report has been prepared and reviewed on behalf of Boca Engineering Co. by:

Christopher Bowness, P.Eng., P.E.

2025-03-28

Issue Date

2025-12-31

Expiry Date



Province of British Columbia
Permit to Practice No.: 1002012



Province of Ontario

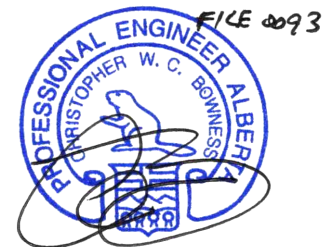

Province of Alberta
Permit to Practice Stamp in ATTACHMENT 5,
Section ALBERTA: 2019 NBC (AE)

EVALUATION REPORT TERMS:

- This report is a general evaluation of the building code section requirements as identified and applies only to the samples that were evaluated. It does not imply any endorsement or warranty, nor that the signatory Engineer is the Designer of Record of any construction project for which the information is used.
- This Evaluation Report expires Dec. 31, 2025, open to renewal. Up to the renewal date, the report is valid until such time as the named product(s) changes, the Quality Assurance Agency changes, or provisions of the Code that relate to the product change.

CERTIFICATION OF INDEPENDENCE:

- Boca Engineering Co., its employees and shareholders, do not have, nor do they intend to or will acquire, a financial interest in any company manufacturing or distributing products that they evaluate.
- Boca Engineering Co. is not owned, operated or controlled by any company manufacturing or distributing products that they evaluate.



CONTENTS:	PAGE:
Product Evaluation.....	3
Attachments.....	8
ATTACHMENT 1: MATERIAL PROPERTIES	8
ATTACHMENT 2: ASSEMBLY WIND PRESSURE TABLES	10
ATTACHMENT 3: ASSEMBLY DIAGRAMS	14
ATTACHMENT 4: DISCUSSION OF LIMIT STATES DESIGN PROCEDURE	24
ATTACHMENT 5: NATIONAL TO PROVINCIAL CODE CROSS-REFERENCES	26
BRITISH COLUMBIA: 2024 BCBC	26
ONTARIO: 2024 OBC [Last Revision: May 2024]	27
ALBERTA: 2023 NBC (AE)	28

Product Evaluation

1.0 PRODUCT DESCRIPTION:

Fastplank Systems are aluminum siding planks and soffit coverings with fastening clips and trim accessories, serving as an exterior wall covering. Planks are cold-formed from 3/64-inch thick aluminum with a V-Notch™ profile, available in widths of 4-inch or 6-inch and lengths of 16-ft. The plank exterior surface is typically finished with a powder-coat paint in a variety of colors.

1.1 MATERIAL PROPERTIES:

The materials properties of Fastplank Systems are provided in *ATTACHMENT 1: MATERIAL PROPERTIES* of this report.

2.0 INSTALLATION:

The siding planks and soffit coverings as described in Section 1 shall be installed in accordance with the manufacturer’s installation instructions, NBCC, BCBC, OBC, and NBC (AE) subject to the Limitations stated within this report.

3.0 CODE SECTIONS REVIEW:

<u>NBCC Div. B</u>	<u>Description</u>
<u>Section</u>	

Part 3/4/5

Div A	Determination of Noncombustibility
--------------	---

1.4.1.2.(1)	FastPlank Systems components (without paint finish) were tested to CAN/ULC S114 and found to conform to the Code definition of <i>noncombustible</i> .
--------------------	--

3.1.4.8(1)(a)	Exterior Cladding, Combustible Construction
----------------------	--

FastPlank applications conform to article 3.1.4.8.(1)(a). See this report comments to section Div A 1.4.1.2(1).

3.1.5.1.(1)	Noncombustible Materials
--------------------	---------------------------------

See this report comments section Div A 1.4.1.2(1).

3.1.5.2	Minor Combustible Components
----------------	-------------------------------------

Article 3.1.5.2.(1)(a) allows paint to be applied to noncombustible components.



- 3.1.7.1 Determination of (Fire-Resistance) Ratings**
See section 5 of this report.
- 3.1.12.1.(1) Determination of (Flame-Spread and Smoke Developed Classification) Ratings**
See section 5 of this report.
- 3.2.3.16.1 (a) Protection of Soffits**
Soffit covering plank is non-combustible and greater than 0.38mm thick. See commentary to Div A 1.4.1.2.(1).
- 4.1.3.5 Limit States Design, Deflection**
Structural testing and engineering studies of wall assemblies with FastPlank Systems have been conducted and reported in Boca Engineering report 0093-11-1. It is found that when installed with the manufacturer's instructions and tested assembly details listed in *ATTACHMENT 2: ASSEMBLY WIND PRESSURE TABLES* for storey heights up to 3.28 m (10 ft), with building frames structurally designed to Part 4, that the cladding materials do not become damaged or dislodged under these limitations: Out of plane lateral load (wind) wall bending limit of L/180 [18 mm (3/4-inch)].
- 4.1.7.1.(5) Wind Load, Exterior Cladding Strength Attachment**
See wind load assembly performance in *ATTACHMENT 2: ASSEMBLY WIND PRESSURE TABLES* of this report, developed following the design methods of article 4.1.7.3.
- 4.3.5.1 Design Basis for Aluminium**
FastPlank Systems conform to CAN/CSA S157/S157.1, having carried out the design verification by testing procedure as outlined in CSA S157-17, Section 22 Testing. See further information in this report *ATTACHMENT 4: DISCUSSION OF LIMIT STATES DESIGN PROCEDURE*.
- 5.1.4.1 Resistance to Structural and Environmental Loads**
The contents of this evaluation report cover the intent of demonstrating compliance to this article.
- 5.1.4.2 Resistance to Deterioration**
FastPlank Cladding complies with material specifications CGSB 93.1 and 93.2 which includes testing to ASTM B117 for 1000 hrs of salt spray exposure and found to have no visible deleterious effects. See *ATTACHMENT 1: MATERIAL PROPERTIES*.
- 5.2.1.3.(3) Environmental (Wind) Load and Transfer Calculations**
The wind load calculations in this report conform to article 4.1.7.
- 5.6.1.1 Required Protection from Precipitation**
The FastPlank aluminum cladding systems' primary function satisfies this article. See section 5.6.2.1 comments of this report.
- 5.6.2.1 Sealing and Drainage**
FastPlank siding systems, when installed per manufacturer's instructions, generally satisfy article 5.6.2.1.(1)(b), as the clips create a minimum 10 mm drainage space between the back of the cladding



panel and the face of the wall sheathing. Guidance of environmental conditions (moisture index) where prescriptive cladding installations require a second plane of protection with capillary break is given in Div B, article 9.27.2.2.(5).

5.9.1.1 Compliance with Applicable Standards

FastPlank installations conform to the requirements of CAN/CGSB 93.1 and 93.2 as referenced in Table 5.9.1.1.

5.9.3.5 Water Penetration

The FastPlank siding systems have been tested and found to meet the requirements of the ASTM E331 water penetration test that is cited in this article, tested at pressure differentials of 0.3 kPa (6.2 psf), 0.575 kPa (12 psf) and 0.958 kPa (20 psf).

A-5.9.3.2.(1) Structural and Environmental Loads

This article states that the applicable laboratory test method for demonstrating adequate structural performance of fenestration (cladding) assemblies is ASTM E330, which is the test method that was used to determine the wind pressure performance of the cladding systems.

Part 9

9.4.1.1(1)(c)(ii) Structural Design Requirements and Application Limits

The design methodology in this evaluation for determining conformance to Part 9 has been performed in accordance with article 9.4.1.1.(1)(c)(ii) using the loads and deflection limits specified in Part 4.

9.10.3.1(1)(a) Fire-Resistance and Fire-Protection Ratings

Refers to test methods in Part 3. See section 3.1.7.1 comments of this report.

9.10.3.2(1) Flame-Spread Ratings

Refers to test methods in Part 3. See section 3.1.12.1.(1) comments of this report.

9.10.6.1 Combustible Elements in Noncombustible Construction, Construction Types

FastPlank Systems components (without paint finish) were tested to CAN/ULC S114 and found to conform to the Div A 1.4.1.2(1) definition of *noncombustible* as referenced in article 3.1.5.

9.10.12.4 (3)(a) Protection of Soffits

Soffit covering meets 9.10.12.4 (3)(a) as mentioned in report comments section Div A 1.4.1.2(1).

9.27.1.1(1) General, Application, Cladding

The FastPlank aluminum siding plank and soffit covering system complies with the application sentences of Subsections 9.27.2 to 9.27.12.

The plank/clip attachment to framing method has been evaluated in accordance with article 9.27.1.1.(1)(b) to Part 5.

9.27.2.2(1)(a) Minimum Protection from Precipitation Ingress

The plank/clip attachment to framing method creates a continuous 10 mm air space between the back of the cladding and sheathing, forming a capillary break.



9.27.11.1 Material Standards, Metal

Fastplank systems conform to CGSB-93.2-M, *Prefinished Aluminum Siding, Soffits, and Fascia for Residential Use*. See this report *ATTACHMENT 1: MATERIAL PROPERTIES*.

3.1 SUPPLEMENTAL TESTING:

Supplemental testing to national standards that are not directly referenced in the NBCC, where the product performance results may be useful in demonstrating the objectives of the NBCC:

AAMA 508-21 Voluntary Test Method and Specification for Pressure Equalized Rain Screen Wall Cladding Systems

A Fastplank siding installation has been tested to and meets the criteria of AAMA 508-21, as further detailed in BOCA report 0093-17-2.

4.0 LIMITATIONS:

1. This Evaluation is for the base code requirements of the building system as addressed in this report. In some building applications, additional performance objectives may be required by Code which must be addressed in the building design for those specific cases.
2. Design calculations, drawings, and special inspections are to be furnished for building projects by registered professionals as required by the respective jurisdictional authorities and Codes.
3. Wall framing and sheathing to which the siding is attached must be designed and installed for the applicable wind pressure and other climate and occupancy loads as required by Code for the construction project. Where framing and sheathing details are provided in this report, they represent the minimum tested or calculated materials for the required strength of attachment for the wall cladding. The wall framing structural design and performance are outside the scope of this report.
4. The response of cladding to Seismic loads has not been considered in this evaluation.
5. Wall assemblies with FastPlank siding, to achieve the wall assembly water-resistance performance standards as stated in this report must be constructed with sheathing, sheathing membrane, water-resistive barrier and flashing in conformance with the NBCC.
6. The Ruspert-coated corrosion-resistant screws supplied with Fastplank systems must be used for installation onto wood or steel frame assemblies in conformance with NBCC.
7. The designer is responsible for designing the soffit so that the exterior roof ventilation meets code (9.19.1.2).
8. Components of the wall assembly other than the exterior cladding may be combustible and must comply with the requirements of the applicable NBCC code sections.

5.0 FIRE CLASSIFICATION:

Summary of fire performance classifications found by testing to code referenced standards:

CAN/ULC S114-18: Unfinished plank meets the definition of non-combustible.

CAN/ULC S102-18: Flame Spread Index (FSI): 0, Smoke Developed Index (SDI): 30

CAN/ULC S101-14: Fire Resistance Rating: 1 hr listing by Intertek. Rating is exclusive to details published by the listing agency. Where wall assembly fire rating is required, FastPlank's design listing may be found at https://bpdirectory.intertek.com/pages/DLP_Search.aspx.

6.0 QUALITY ASSURANCE ENTITY:

The products evaluated in this report are surveyed at the approved manufacturing locations with third-party quality assurance inspections and product certification labeling by Intertek.



7.0 MANUFACTURING PLANTS:

The manufacturing plants of cladding materials covered in this evaluation report are located in: Calgary, AB.

8.0 LABELING:

Labeling shall be in accordance with the requirements of and bear the certification mark of the Accredited Quality Assurance Agency.

9.0 REFERENCE TESTING AND EVALUATION DOCUMENTS:

Entity	Entity Accreditation ¹	Standards	Report No.	Issue Date
Intertek	SCC Lab No. 54	CAN/ULC-S102	104572653COQ-005 R0	2021-03-18
Intertek	SCC Lab No. 54	CAN/ULC S114	104572653COQ-007 R0	2021-04-27
Intertek	SCC Lab No. 54	ASTM E331	104634983COQ-002A	2021-07-23
Intertek	SCC Lab No. 54	ASTM E330	104352097COQ-002	2021-05-06
Intertek	SCC Lab No. 54	ASTM E330	104352869COQ-022A	2021-08-10
Intertek	SCC Lab No. 54	ASTM E330	105745090COQ-001A	2024-04-24
Intertek	SCC Lab No. 54	ASTM E330	105642282COQ-002	2024-04-24
Boca Engineering	Note 2	ASTM E330	0093-5-1	2022-05-10
Boca Engineering	Note 2	ASTM E330	0093-11-2	2023-06-19
Boca Engineering	Note 2	AAMA 508	0093-17-1	2023-07-18
Intertek	IAS TL-144	ASTM B117	L2210.01-106-31 R0	2021-09-15
Intertek	IAS TL-144	AAMA 508-21	105139889COQ-012	2023-05-25
Intertek	IAS TL 144	CAN/CGSB 93.1, 93.2	P0500.01-106-31 R2	2023-04-12
Intertek	IAS TL 144	CAN/CGSB 93.2	R3808.01-109-18-R0	2025-02-24
Intertek	SCC No. 10014	Product Certification	Spec ID 68062	2025-03-28
Intertek	IAS AA-647	Quality Assurance	Spec ID 68062	2025-03-28

1. Testing, certification, evaluation, and inspection agencies referenced have been verified to be accredited by Standards Council of Canada (www.scc.ca), A2LA (www.a2la.org) or International Accreditation Service (www.iasonline.org) for the applicable scope, in good standing on the date of the evaluation, in accordance with ISO 17025 and ISO 17020 international standards for testing and inspection bodies.
2. Professional Engineer sealed report.



Attachments

ATTACHMENT 1: MATERIAL PROPERTIES

Table 1: Fastplank System's Physical Properties

Property	Method	Result			Requirement	Compliance
Material Properties per CGSB 93.1						
Coating Quality	CGSB 93.1 Section 7.2.1	Meets as Stated			Commercially smooth and uniform in appearance, free from cracks, pinholes, blisters, and flaking	Pass
Colour	ASTM D1729	-			Commercially smooth and uniform in appearance, and match colour specified	Pass
Gloss	ASTM D523-67 (1972)	60°	10.1		As reported	As reported
		85°	10.1		As reported	As reported
Coating Thickness (mil)	ASTM D1400	Front	5.55		> 20µm	As reported
		Back	0.99			As reported
Impact Resistance	CGSB 93.1 Section 7.2.2	No visible rupture			No visible rupture	Pass
Film Adhesion	CGSB 93.1 Section 7.2.3	Front	No removal of coating		No removal of coating	Pass
		Back	No removal of coating		No removal of coating	
Film Hardness	CGSB 93.1 Section 7.2.4	H			≥ HB	Pass
Flexibility	CGSB 93.1 Section 7.2.5	No evidence of cracking or flaking			No evidence of cracking or flaking	Pass
Salt Spray Resistance, mm 1000 hrs of exposure	CGSB 93.1 Section 7.2.6	Front	0.0	No corrosion, blisters or other deleterious effects	≤ 1.5	Pass
		Back	0.0		≤ 1.5	
Humidity Resistance	ASTM D2247/ASTM D714	Front	No blisters		No blisters	Pass
		Back	No blisters		No blisters	
Durability	CGSB 93.1 Section 7.2.7	No chalking, checking, or cracking			No chalking, checking, or cracking	Pass
Material Properties per CGSB 93.2						
Siding General Requirements	CGSB 93.2 Section 5	Meets As Stated			Uniform in profile, pattern, color, gloss, and free from defects	Pass
Siding Raw Coil Thickness	CGSB 93.2 Section 6.4	Average: 60 mil			Report as found	Pass
Siding Penetration by Drop Impact	CGSB 93.2 Section 8.2.1	Meets As Stated			< 10 mm impact indentation	Pass
					< 13 mm impact indentation	
Siding Cantilever	CGSB 93.2 Section 8.2.2	2,438mm, specimen touched the ground but did not buckle			Support 1 kg 1,100 mm from fulcrum without buckling	Pass



Siding Buckling Resistance	CGSB 93.2 Section 8.2.3	Meets As Stated	Support a minimum of 14.0 kg load without buckling	Pass	
Soffit General Requirements	CGSB 93.2 Section 5	Meets As Stated	Uniform in profile, pattern, color, gloss, and free from defects	Pass	
Soffit Raw Coil Thickness	CGSB 93.2 Section 6.4	Average: 57 mil	Report as found	Pass	
Soffit Cantilever	CGSB 93.2 Section 8.2.2	2540 mm from the buckling point	Support 1 kg 1,400 mm from fulcrum without buckling	Pass	
Soffit Buckling Resistance	CGSB 93.2 Section 8.2.3	90.2 kg	Support a minimum of 14.0 kg load without buckling	Pass	
Soffit Wind Load	CGSB 93.2 Section 8.2.4	Meets As Stated	Resist a minimum pressure of 265 Pa without buckling	Pass	
General Material Properties					
Tensile Strength (psi)	ASTM E8	Yield	26,171 psi (180 MPa)	Report Value	Pass
		Ult.	30,298 psi (209 MPa)		
		MOE	8.6 x 10 ⁶ psi (59,295 MPa)		
Corrosion Resistance of Coated Surface, Mean Creepage (mm)	ASTM D1654	Front	0 mm	Absence of rust, blistering, adhesion loss, after 1000 hrs of ASTM B117 Salt Fog exposure	Pass
		Back	0 mm		
		No visible deleterious effects			
Non-Combustibility	CAN/ULC S114	1. Temperature rise not to exceed 36° C 2. No flaming during final 14.5 min. 3) Max mass loss of 20%		Meets definition of Non-combustible	Pass
Flame Spread Index	CAN/ULC S102	0		-	-
Smoke Developed Index	CAN/ULC S102	30		-	-
Wall Assembly Tests, Performance Values¹					
Wind Resistance (psf)	ASTM E330	Design pressure values of 43 – 140 psf (2.11 – 6.70 kPa), dependant on assembly details and installation conditions			
Water Penetration Resistance	ASTM E331	No leakage observed after 15-min pressurized rain exposure at 0.3 kPa (6.2 psf), 0.575 kPa (12 psf) and 0.958 kPa (20 psf)			
Pressure Equalized Rain Screen	AAMA 508	Meets criteria of test standard definition of Pressure Equalized Rain Screen			
Fire Endurance	CAN/ULC S101	Fire resistance rating of 1 hr			

1. Wall assembly tests results are dependant on plank models, installation components and environmental conditions consistent with tested details. See Fastplank’s document library of Engineering and Certifications reports for further details.

ATTACHMENT 2: ASSEMBLY WIND PRESSURE TABLES

User’s Guide to Exterior Wall Cladding Wind Pressure and Wind Speed Tables:

The FastPlank siding and soffit covering wind pressures and wind reference velocity conversion tables have been developed to assist users with determining acceptable installation details for a range of wall construction components, building dimension plans, and site and environmental conditions.

Wind reference velocity conversion tables have been prepared following the design methodology of NBCC article 4.1.7, for enclosed buildings with a maximum height of 30m (100 ft) with a topographic factor set to unity. These settings are typical of many installations. All design details must agree with the information within the table and table notes to be considered valid. If the actual site, building dimension or climatic conditions (including the given variables) differ from those prescribed, the maximum design pressure values may be used to calculate adjusted reference velocity pressure limits.

When the design pressure has been pre-determined by a design professional, the user only needs to check that the installation detail’s maximum design pressure is equal to or greater than the actual.

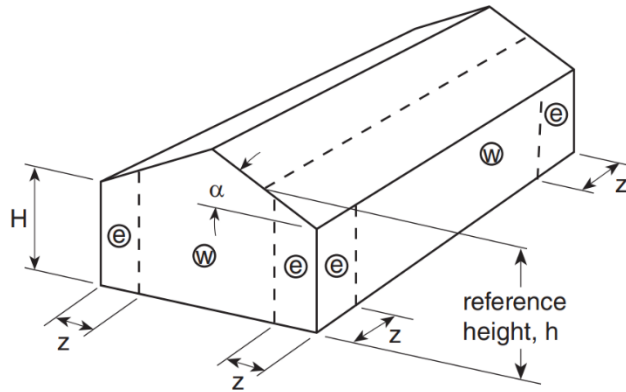

(1) End-zone width z is the lesser of 10% of the least horizontal dimension and 40% of height, H , but not less than 4% of the least horizontal dimension or 1 m.

(2) e : End-zone, w : Field.

Figure 1: Wind Pressure Zone Diagram as represented in 2020 NBCC for use in conjunction with Tables 2 & 3.



Table 2.1: Wind Pressure Assembly Configurations for FastPlank P44V and P46V Planks - Wall Height Limit of 3m (10 ft), Bending Deflection Limit of L/180¹

Assembly Number ²	Configuration ^{3,4}	Fastener Substrate	Min. Framing ^{5,6,7}	Fastener ⁸	Min. Sheathing ^{9,10}	Max. Design Pressure (kPa) ^{11,12,13}
1	Clips @ 32" O.C. straight	Stud	2x4 SPF No. 2 wood studs @ 16" o.c.	#10 - 1-1/2" screw	7/16" OSB	2.11
2	Clips @ 32" O.C. straight	Stud	1-5/8 x 3-5/8 33 ksi 18 ga. steel stud @ 16" o.c.	#12 - 1-1/2" screw	7/16" OSB	2.11
3	Clips @ 32" O.C. straight	Sheathing	2x4 SPF No. 2 wood studs @ 16" o.c.	#10 - 1-1/2" screw	7/16" OSB	2.11
4	Clips @ 32" O.C. straight	Sheathing	1-5/8 x 3-5/8 33 ksi 18 ga. steel stud @ 16" o.c.	#12 - 1-1/2" screw	7/16" OSB	2.11
5	Clips @ 32" O.C. straight	Sheathing	2x4 SPF No. 2 wood studs @ 16" o.c.	#10 - 1-1/2" screw	5/8" Plywood	3.30
6	Clips @ 32" O.C. straight	Sheathing	1-5/8 x 3-5/8 33 ksi 18 ga. steel stud @ 16" o.c.	#12 - 1-1/2" screw	5/8" Plywood	3.30
7	Clips @ 32" O.C. staggered	Stud	2x4 SPF No. 2 wood studs @ 16" o.c.	#10 - 2-1/2" screw	7/16" OSB + 5/8" Ext. Gypsum	3.37
8	Clips @ 32" O.C. staggered	Stud	2x SPF No. 2 wood studs @ 16" o.c.	#10 - 1-1/2" screw	7/16" OSB	3.97
9	Clips @ 16" O.C. straight	Stud	2x6 SPF No. 2 wood studs @ 16" o.c.	#10 - 1-1/2" screw	7/16" OSB	5.55
10	Clips @ 16" O.C. straight	Stud	1-5/8" x 6" 33 ksi (230 MPa) 18 ga. steel stud @ 16" o.c. ⁶	#12 - 1-1/2" screw	7/16" OSB	5.55
11	Clips @ 32" O.C. staggered	Stud	1-5/8 x 3-5/8 33 ksi 18 ga. steel stud @ 16" o.c.	#12 - 1-1/2" screw	1/2" Ext. Gypsum	3.32
12	Clips @ 32" O.C. staggered	Stud	1-5/8 x 3-5/8 33 ksi 18 ga. steel stud @ 16" o.c.	#12 - 1-1/2" screw	7/16" OSB	3.97
13	Clips @ 16" O.C. straight	Stud	2x6 SPF No. 2 wood studs @ 16" o.c.	#10 - 1-1/2" screw	5/8" Plywood	6.70
14	Clips @ 16" O.C. straight	Stud	1-5/8" x 6" 50 ksi (345MPa) 16 ga. steel stud @ 16" o.c. ²⁶	#12 - 1-1/2" screw	5/8" Plywood	6.70
15	Clips @ 16" O.C. straight	Furring into Concrete/CMU ^{23,24}	Vertical wood furring @ 16" o.c.; 2x2 SPF No.2 wood or better ²¹	#12 - 1-1/2" screw to wood furring; KWIK HUS-EZ (KH-EZ) Screw Anchor @ 16" o.c into Concrete ^{20,22,25} /KWIK BOLT HLC Sleeve Anchor Carbon Steel into Grout-filled or hollow CMU @ 16" o.c.; ^{19,22,25}	N/A	6.70
16	Clips @ 16" O.C. straight	Furring into Concrete/CMU ^{23,24}	7/8"x1-1/4" 18ga 33ksi (230 MPa) steel hat Channel; <u>OR</u> Z 1-3/4"x1-3/4"x 1.09 lb/ft 6005 or 6031 aluminum alloy z-girt	#12 - 3/4" screw to metal furring; KWIK HUS-EZ (KH-EZ) Screw Anchor @ 16" o.c. into concrete ^{20,22,25} /KWIK BOLT HLC Sleeve Anchor Carbon Steel into Grout-filled or hollow CMU @ 16" o.c. ^{19,22,25}	N/A	6.70
17	Clips @ 16" O.C. straight	CMU ²⁴	Hollow <u>or</u> Grout-filled Concrete Masonry Unit (CMU)	KWIK BOLT HLC Sleeve Anchor Carbon Steel into Grout-filled or hollow CMU @ 16" o.c. ^{19, 22,25}	N/A	6.70
18	Clips @ 16" O.C. straight	Concrete ²³	Concrete ²³	" KWIK HUS-EZ (KH-EZ) Screw Anchor @ 16" o.c. ^{20,22,25}	N/A	6.70



Table 2.2: Wind Assembly Details with FastPlank P47V Soffit covering planks

Assembly Number ²	Configuration ^{3,4}	Fastener Substrate	Min. Framing ^{5,6,7}	Fastener ⁸	Min. Sheathing ^{9,10}	Max. Design Pressure (kPa) ^{11,12,13}
19	Clips @ 24" O.C. straight	Joist	2x6 SPF No. 2 lumber @ 24" o.c.	#10 - 1-1/2" screw	N/A	4.55

Table 3.1: Maximum Reference Velocity Pressure of P44V and P46V Wall Cladding Installed at Various Building Heights and Exposure Categories – NBCC 2020 - Wall Height Limit of 3m (10 ft), Bending Deflection Limit of L/180¹

Assembly Number ²	Max. Design Pressure p (kPa) ^{11,12,13}	Maximum Reference Velocity Pressure $q_{1/50} \leq$ (kPa) ^{11,14,15,16}									
		Maximum height of installed cladding (m) ¹⁷									
		Open Terrain, End-zone ¹⁸					Open Terrain, Field ¹⁸				
		6 m	12 m	20 m	24 m	30 m	6 m	12 m	20 m	24 m	30 m
1,2,3,4	2.11	-0.87	-0.78	-0.52	-0.50	-0.48	-0.97	-0.88	-0.66	-0.64	-0.61
5,6	3.30	-1.00	-1.00	-0.82	-0.79	-0.75	-1.00	-1.00	-1.00	-1.00	-0.96
7	3.37	-1.00	-1.00	-0.83	-0.80	-0.77	-1.00	-1.00	-1.00	-1.00	-0.98
8	3.97	-1.00	-1.00	-0.98	-0.95	-0.90	-1.00	-1.00	-1.00	-1.00	-1.00
9,10	5.55	-1.00	-1.00	-1.00	-1.00	-1.00	-1.00	-1.00	-1.00	-1.00	-1.00
11	3.32	-1.00	-1.00	-0.82	-0.79	-0.76	-1.00	-1.00	-1.00	-1.00	-0.96
12	3.37	-1.00	-1.00	-0.83	-0.80	-0.77	-1.00	-1.00	-1.00	-1.00	-0.98
13,14,15,16,17,18	6.70	-1.00	-1.00	-1.00	-1.00	-1.00	-1.00	-1.00	-1.00	-1.00	-1.00
		Rough Terrain, End-zone ¹⁸					Rough Terrain, Field ¹⁸				
1,2,3,4	2.11	-1.00	-1.00	-0.74	-0.70	-0.66	-1.00	-1.00	-0.94	-0.89	-0.84
5,6	3.30	-1.00	-1.00	-1.00	-1.00	-1.00	-1.00	-1.00	-1.00	-1.00	-1.00
7	3.37	-1.00	-1.00	-1.00	-1.00	-1.00	-1.00	-1.00	-1.00	-1.00	-1.00
8	3.97	-1.00	-1.00	-1.00	-1.00	-1.00	-1.00	-1.00	-1.00	-1.00	-1.00
9,10	5.55	-1.00	-1.00	-1.00	-1.00	-1.00	-1.00	-1.00	-1.00	-1.00	-1.00
11	3.32	-1.00	-1.00	-1.00	-1.00	-1.00	-1.00	-1.00	-1.00	-1.00	-1.00
12	3.37	-1.00	-1.00	-1.00	-1.00	-1.00	-1.00	-1.00	-1.00	-1.00	-1.00
13,14,15,16,17,18	6.70	-1.00	-1.00	-1.00	-1.00	-1.00	-1.00	-1.00	-1.00	-1.00	-1.00

Table 3.2: Maximum Reference Velocity Pressure of P47V Wall Cladding Installed at Various Building Heights and Exposure Categories – NBCC 2020

Assembly Number ²	Max. Design Pressure p (kPa) ^{11,12,13}	Maximum Reference Velocity Pressure $q_{1/50} \leq$ (kPa) ^{11,14,15,16}									
		Maximum height of installed cladding (m) ¹⁷									
		Open Terrain, End-zone ¹⁸					Open Terrain, Field ¹⁸				
		6 m	12 m	20 m	24 m	30 m	6 m	12 m	20 m	24 m	30 m
19	4.55	-1.00	-1.00	-1.00	-1.00	-1.00	-1.00	-1.00	-1.00	-1.00	-1.00
		Rough Terrain, End-zone ¹⁸					Rough Terrain, Field ¹⁸				
19	4.55	-1.00	-1.00	-1.00	-1.00	-1.00	-1.00	-1.00	-1.00	-1.00	-1.00

Table notes begin next page.



Tables 2 - 3, Notes:

- 1) The siding has been tested to the published maximum design pressures at the respective bending limitation of $L/180$ for wall heights of up to 3 m (10 ft), unless otherwise noted. Where framing and sheathing details are provided in these tables, this represents only the minimum tested or calculated materials for the required strength of attachment of the wall cladding. Primary structural building loads and capacity of the building framing is outside the scope of this table and must be designed and installed for the applicable wind, climate and occupancy loads as required by the Code for the construction project. See Attachment 4 of the report for further discussion.
- 2) Further assembly details per Table 2.1 and 2.2 and additional details in the assembly diagrams of this report are to be followed.
- 3) A straight configuration consists of vertically aligned clips at each plank with horizontal spacing as stated.
- 4) A staggered configuration consists of vertically aligned clips on every second plank with the clip starting locations alternating between the first and second plank rows to create a staggered appearance.
- 5) Wood framing min. nominal member size, to comply with NLGA 2017. May be substituted with i) any larger section dimension of the same material, and/or, ii) any species/grade of 0.42 specific gravity or greater.
- 6) Steel framing to be min. 1-5/8" x 3-5/8", to comply with CSA S136, min. yield strength of 33 ksi (230 MPa) and 18 ga thickness @ 16". May be substituted with i) any larger section dimension of the same material, and/or, ii) any greater yield strength and/or gauge thickness.
- 7) The structural framing and sheathing shall be designed and anchored to provide lateral bracing and properly transfer all loads to the structure. Framing design and installation is the responsibility of the engineer or architect of record for the project of installation.
- 8) Fasteners supplied with FastPlank siding must be used. Wood screws to conform to ASME B18.6.1 and metal screws to conform to ASTM C1513.
- 9) Wood-based Sheathing: Min. 7/16 OSB to comply with CSA O437. May be substituted with min. 15/32 plywood complying with CSA O325 and/or thicker profile of up to nominal 1-inch.
- 10) Gypsum sheathing must comply with ASTM C1396 and be rated by the manufacturer for exterior use; gypsum thickness may not be increased.
- 11) Wind pressures are only valid under the design conditions stated. For other site and/or building dimensions, designers can use the published maximum design pressure to determine allowable wind speeds following article 4.1.7.
- 12) The maximum design pressure is determined from tested assemblies as the ultimate negative test pressure divided by 2. In limit states design, the safety factor of 2 applied to the ultimate strength may be regarded as equal to the wind load factor divided by resistance factor.
- 13) The maximum design pressure must not exceed the unfactored pressure determined by article 4.1.7.3.
- 14) A maximum $q_{1/50}$ value of 1.0 has been applied.
- 15) N/A indicates that the installation condition is not acceptable within the design limits of the table.
- 16) The maximum $q_{1/50}$ pre-calculated published values with the inputs of: ULS $I_w = 1$, SLS $I_w = 0.75$, $C_t = 1$, $C_{ei} = -0.45$ to $+0.3$. The values of C_e , C_g , C_p , C_{gi} , C_{pi} were determined using the procedures of article 4.1.7.3.
- 17) Interpolation not permitted. For heights in between those listed, use next highest height column.
- 18) Wind exposure categories as defined in article 4.1.7.3(5) as displayed in Figure 1.
- 19) Min. 1" nominal embedment depth and 12" nominal edge distance.
- 20) Min. 1-5/8" nominal embedment depth and 2-1/2" nominal edge distance.
- 21) Assembly No. 15 wood furring is designed for dry service conditions and untreated.
- 22) Concrete anchors to conform to ASTM A307 or ASTM A36 grade as per CSA A23.3.
- 23) Concrete shall have a minimum 28-day compressive strength of 20 MPa and conform to CSA A23.3, Design of Concrete Structures.
- 24) Concrete Masonry Unit (CMU) shall have a minimum 28-day compressive strength of 10 MPa and conform with CSA A304. Grout shall have a minimum 28-day compressive strength of 15 MPa and conform with CSA A371.
- 25) Min. 1/4" nominal anchor diameter.
- 26) Assembly No. 14 is only applicable for wall heights up to a maximum of 9ft, with min. 1-5/8" x 6" steel framing, 50 ksi (345 MPa) and 16 ga thickness @ 16", on centre. May be substituted with i) any larger section dimension of the same material, and/or, ii) any greater yield strength and/or gauge thickness.



ATTACHMENT 3: ASSEMBLY DIAGRAMS

Begins next page.



FASTPLANK CLIP AT EVERY END STUD AND VERTICAL TRIM

VERTICAL TRIM
6" OR 4" ALUMINUM SIDING

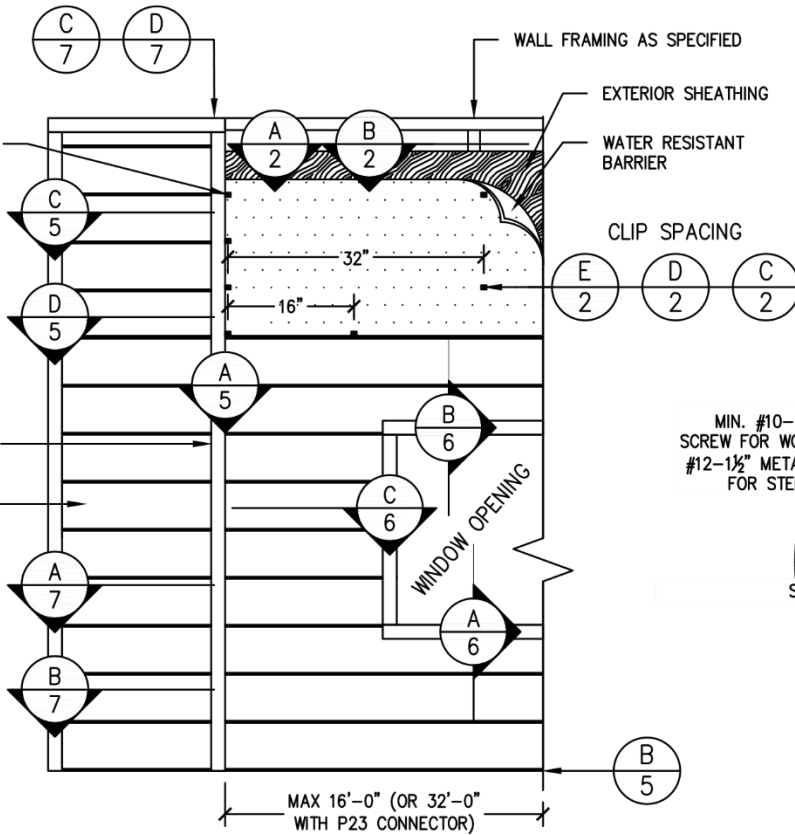

A
1
WALL ELEVATION
NOT-TO-SCALE

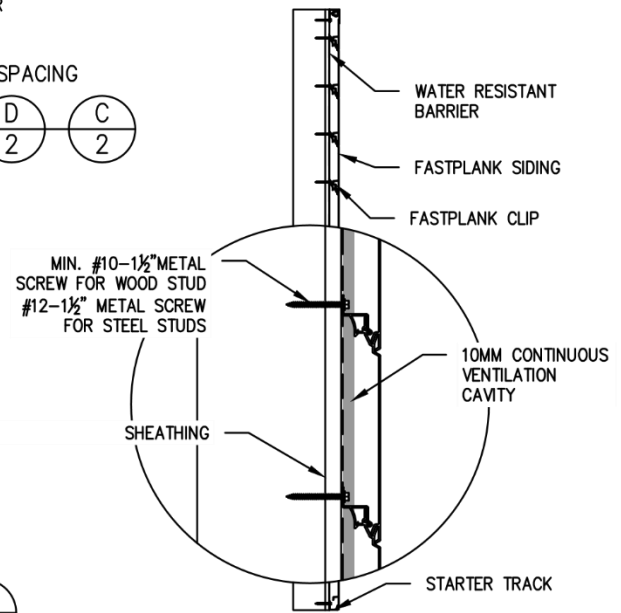

B
1
FASTPLANK WALL ELEVATION
NOT-TO-SCALE

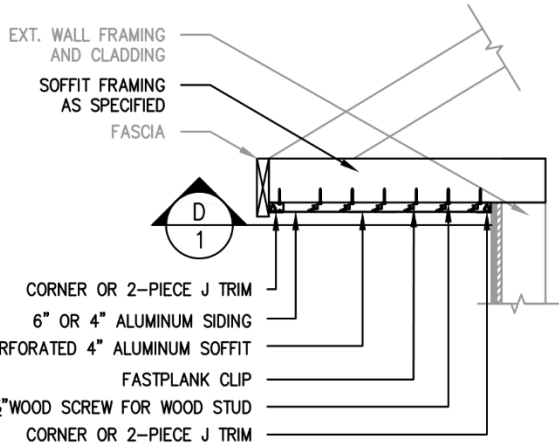

C
1
FASTPLANK SOFFIT ELEVATION
NOT-TO-SCALE | ELEVATION

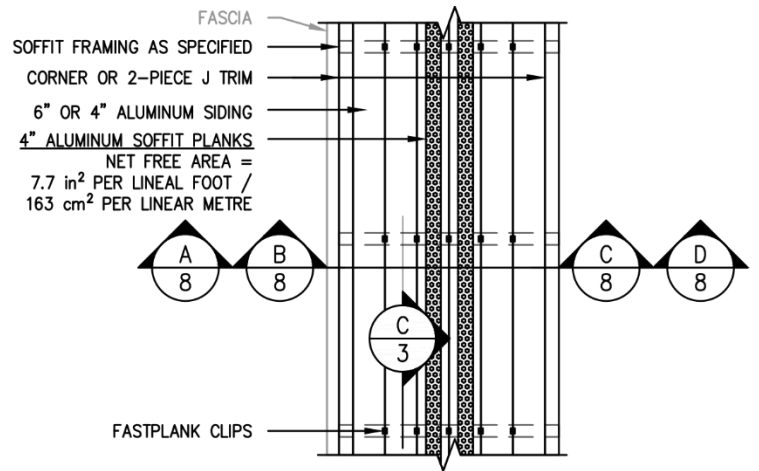

D
1
CLIPS AT 24" O.C STRAIGHT
NOT-TO-SCALE | BOTTOM VIEW

COPYRIGHT © 2024 RESERVED. THESE PLANS AND DESIGNS ARE AT ALL TIMES THE PROPERTY OF BOCA ENGINEERING TO BE USED FOR THE PROJECT SHOWN. WRITTEN CONSENT IS REQUIRED FROM THE ENGINEER BEFORE ANY REPRODUCTION.

TITLE GENERAL INSTALLATION ASSEMBLY DIAGRAMS	CLIENT ENGAGE BUILDING PRODUCTS FASTPLANK SYSTEMS	PROJECT FASTPLANK SIDING AND SOFFIT NBCC/BCBC/OBC/ABC PRODUCT EVALUATION REPORT			
	DATE DECEMBER 31, 2024	REV. 1	FOR PUBLICATION		CB
DRAWING NO. 6034-SK1	SHEET NO. 1 OF 9	SCALE NOT TO SCALE	DES. CB	DRN. JJ	CHK. CB

DRAWING FOR ENGINEERING EVALUATION
REPORT: 0093-15-3-6034

NOT FOR USE AS CONSTRUCTION DESIGN DOCUMENTS



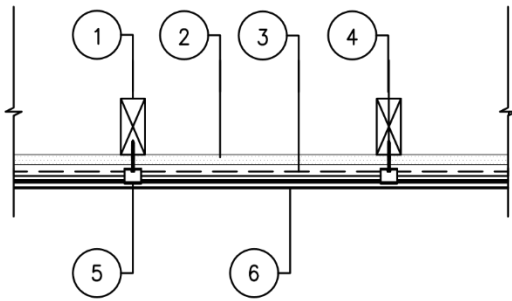

A
2 FASTPLANK OVER WOOD STUDS
NOT-TO-SCALE

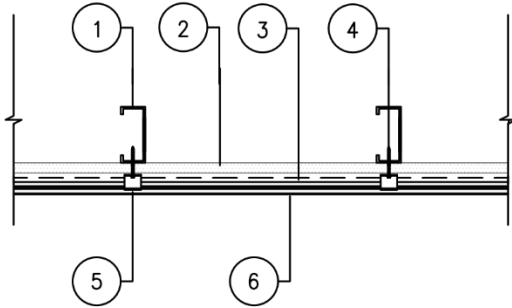

B
2 FASTPLANK OVER STEEL STUDS
NOT-TO-SCALE

LIGHT-FRAMED STUD WALL INSTALLATION INTERIOR TO EXTERIOR	
1	SPF No.2 WOOD STUDS @ 16" O.C. PER EVALUATION REPORT ³
2	SHEATHING PER PER EVALUATION REPORT ³
3	WATER RESISTIVE BARRIER TO CODE
4	MIN. #10 1-1/2" WOOD SCREWS @ EACH CLIP
5	FASTPLANK CLIP PER EVALUATION REPORT ³
6	FASTPLANK SIDING
LIGHT-FRAMED STUD WALL INSTALLATION INTERIOR TO EXTERIOR	
1	STEEL STUDS @ 16" O.C. PER EVALUATION REPORT ³
2	SHEATHING PER EVALUATION REPORT ³
3	WATER RESISTIVE BARRIER TO CODE BY OTHERS
4	MIN. #12 1-1/2" METAL SCREWS @ EACH CLIP
5	FASTPLANK CLIP PER EVALUATION REPORT ³
6	FASTPLANK SIDING

- NOTE:
1. INTERIOR FINISH AND INSULATION TO CODE, NOT SHOWN FOR CLARITY.
 2. FLASHING AT ALL PENETRATIONS TO CODE, NOT SHOWN FOR CLARITY.
 3. REFER TO ENGINEERING EVALUATION REPORT: 0093-15-3-6034

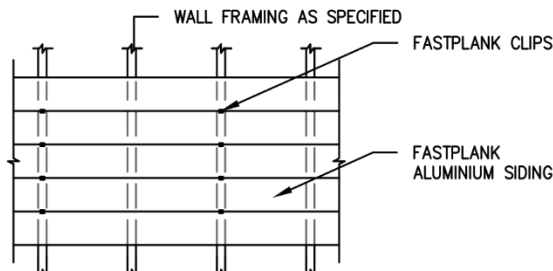

C
2 CLIPS AT 32" O.C STRAIGHT
NOT-TO-SCALE

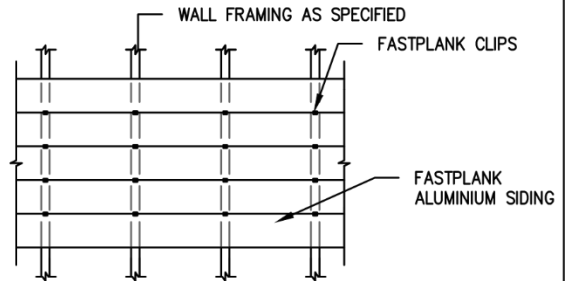

D
2 CLIPS AT 16" O.C STRAIGHT
NOT-TO-SCALE | ELEVATION

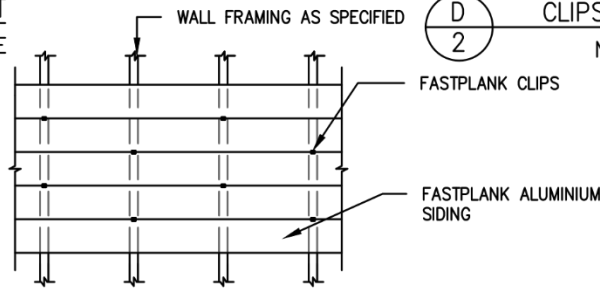

E
2 CLIPS AT 32" O.C STAGGERED
NOT-TO-SCALE | ELEVATION

COPYRIGHT © 2024 RESERVED. THESE PLANS AND DESIGNS ARE AT ALL TIMES THE PROPERTY OF BOCA ENGINEERING TO BE USED FOR THE PROJECT SHOWN. WRITTEN CONSENT IS REQUIRED FROM THE ENGINEER BEFORE ANY REPRODUCTION.

TITLE GENERAL INSTALLATION ASSEMBLY DIAGRAMS	CLIENT ENGAGE BUILDING PRODUCTS FASTPLANK SYSTEMS	PROJECT FASTPLANK SIDING AND SOFFIT NBCC/BCBC/OBC/ABC PRODUCT EVALUATION REPORT				DRAWING FOR ENGINEERING EVALUATION REPORT: 0093-15-3-6034	
		DATE DECEMBER 31, 2024	REV. 1	FOR PUBLICATION		CB	
DRAWING NO. 6034-SK1	SHEET NO. 2 OF 9	SCALE NOT TO SCALE	DES. CB	DRN. JJ	CHK. CB		



DRAWING FOR ENGINEERING
EVALUATION
REPORT: 0093-15-3-6034

NOT FOR USE AS
CONSTRUCTION DESIGN
DOCUMENTS

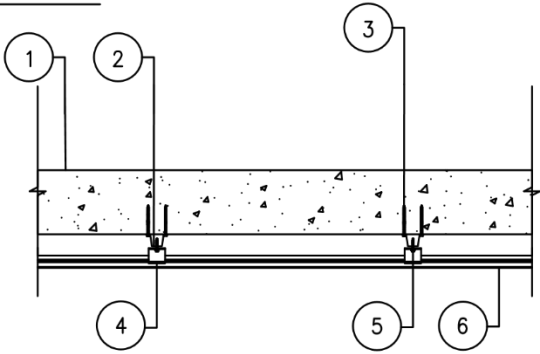

A
3 FASTPLANK OVER CONCRETE WALL
NOT-TO-SCALE | PLAN

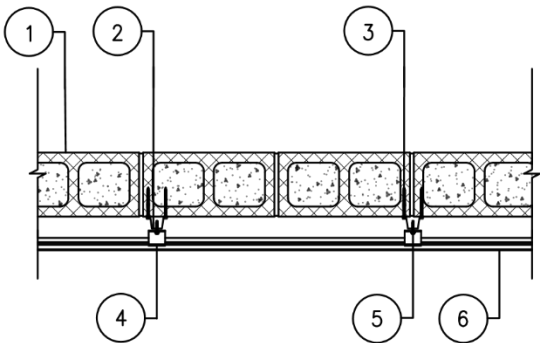

B
3 FASTPLANK OVER CMU WALL
NOT-TO-SCALE | PLAN

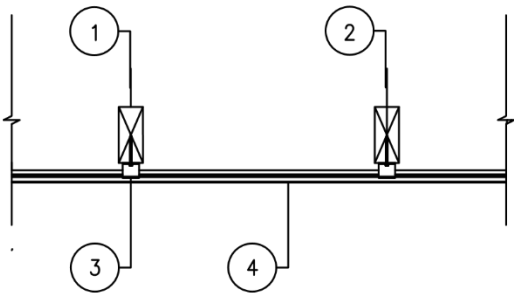

C
3 FASTPLANK SOFFIT OVER WOOD FRAMING
NOT-TO-SCALE | ELEVATION

SOLID CONCRETE WALL INSTALLATION INTERIOR TO EXTERIOR	
1	CONCRETE PER EVALUATION REPORT ³
2	(OPTIONAL) FURRING @ 16" O.C. PER EVALUATION REPORT ³
3	ANCHORS PER EVALUATION REPORT ³ IF FURRING INSTALLED: TAPCON ANCHORS THRU FURRING INTO CONCRETE WALL. IF NO FURRING INSTALLED: TAPCON ANCHORS THRU CLIPS INTO CONCRETE WALL.
4	FASTPLANK CLIP PER EVALUATION REPORT ³
5	IF FURRING INSTALLED: SCREWS INTO WOOD FURRING @ EACH CLIP PER EVALUATION REPORT ³ SCREWS INTO METAL FURRING @ EACH CLIP PER EVALUATION REPORT ³
6	FASTPLANK SIDING

CONCRETE MASONRY UNIT (CMU) WALL INSTALLATION INTERIOR TO EXTERIOR	
1	HOLLOW <u>OR</u> GROUT-FILLED CMU WALL PER EVALUATION REPORT ³
2	(OPTIONAL) FURRING @ 16" O.C. PER EVALUATION REPORT ³
3	ANCHORS PER EVALUATION REPORT ³ IF FURRING INSTALLED: TAPCON ANCHORS THRU FURRING INTO CMU WALL. IF NO FURRING INSTALLED: TAPCON ANCHORS THRU CLIPS INTO CMU WALL.
4	FASTPLANK CLIP PER EVALUATION REPORT ³
5	IF FURRING INSTALLED: SCREWS INTO WOOD FURRING @ EACH CLIP PER EVALUATION REPORT ³ SCREWS INTO METAL FURRING @ EACH CLIP PER EVALUATION REPORT ³
6	FASTPLANK SIDING

LIGHT-FRAMED SOFFIT INTERIOR TO EXTERIOR	
1	WOOD STUD PER EVALUATION REPORT ³
2	MIN. #10 1-1/2" WOOD SCREWS @ EACH CLIP
3	FASTPLANK CLIP PER EVALUATION REPORT ³
4	FASTPLANK SIDING AND/OR SOFFIT

NOTE:

1. INTERIOR FINISH AND INSULATION TO CODE BY OTHERS, NOT SHOWN FOR CLARITY.
2. FLASHING AT ALL PENETRATIONS TO CODE BY OTHERS, NOT SHOWN FOR CLARITY.
3. DRAWING FOR ENGINEERING EVALUATION REPORT: 0093-15-3-6034

COPYRIGHT © 2024 RESERVED. THESE PLANS AND DESIGNS ARE AT ALL TIMES THE PROPERTY OF BOCA ENGINEERING TO BE USED FOR THE PROJECT SHOWN. WRITTEN CONSENT IS REQUIRED FROM THE ENGINEER BEFORE ANY REPRODUCTION.

TITLE GENERAL INSTALLATION ASSEMBLY DIAGRAMS	CLIENT ENGAGE BUILDING PRODUCTS FASTPLANK SYSTEMS	PROJECT FASTPLANK SIDING AND SOFFIT NBCC/BCBC/OBC/ABC PRODUCT EVALUATION REPORT
DATE DECEMBER 31, 2024	REV. 1	FOR PUBLICATION ISSUE
DRAWING NO. 6034-SK1	SHEET NO. 3 OF 9	SCALE NOT TO SCALE
		DES. CB
		DRN. JJ
		CHK. CB

DRAWING FOR ENGINEERING
EVALUATION
REPORT: 0093-15-3-6034

NOT FOR USE AS
CONSTRUCTION DESIGN
DOCUMENTS



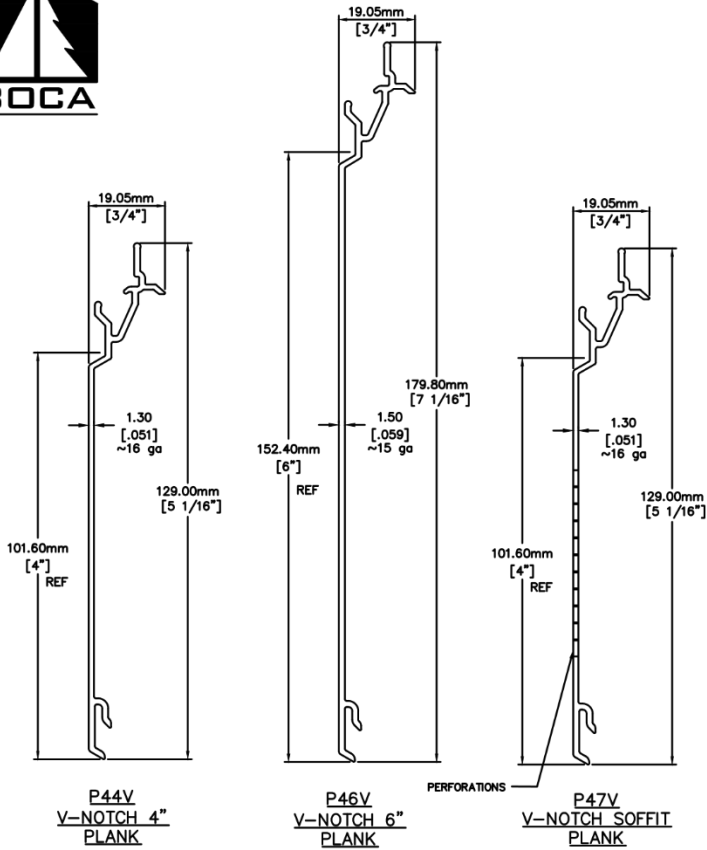

C FASTPLANK V-NOTCH SIDING PLANKS
4 NOT-TO-SCALE

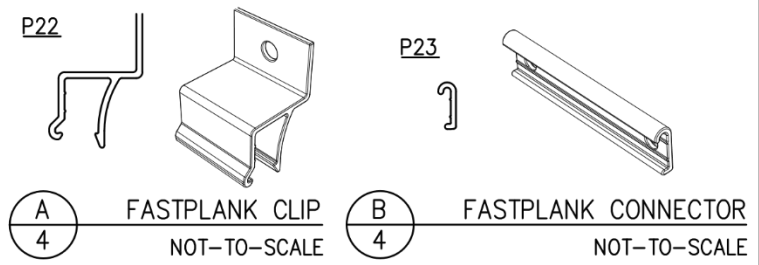

A FASTPLANK CLIP
4 NOT-TO-SCALE

B FASTPLANK CONNECTOR
4 NOT-TO-SCALE

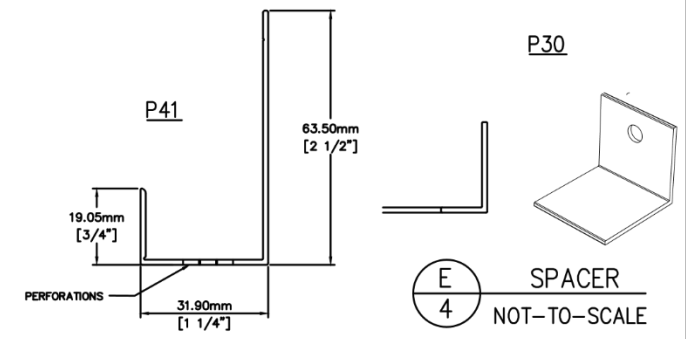

D PERFORATED STARTER TRACK
4 NOT-TO-SCALE

E SPACER
4 NOT-TO-SCALE

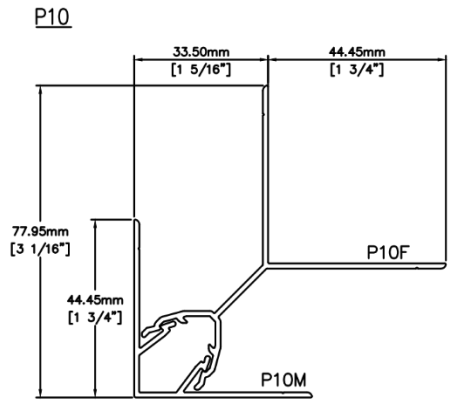

F INSIDE/OUTSIDE CORNER
4 NOT-TO-SCALE

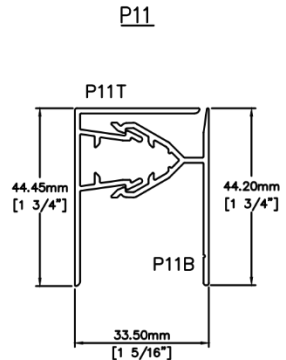

G J-TRIM CLIP
4 NOT-TO-SCALE

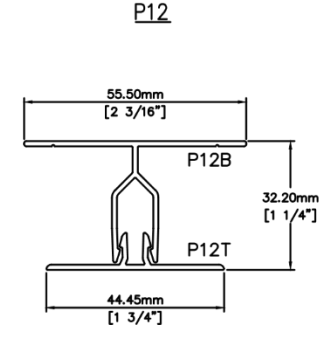

H VERTICAL TRIM
4 NOT-TO-SCALE

COPYRIGHT © 2024 RESERVED. THESE PLANS AND DESIGNS ARE AT ALL TIMES THE PROPERTY OF BOCA ENGINEERING TO BE USED FOR THE PROJECT SHOWN. WRITTEN CONSENT IS REQUIRED FROM THE ENGINEER BEFORE ANY REPRODUCTION.

TITLE GENERAL INSTALLATION ASSEMBLY DIAGRAMS	CLIENT ENGAGE BUILDING PRODUCTS FASTPLANK SYSTEMS	PROJECT FASTPLANK SIDING AND SOFFIT NBCC/BCBC/OBC/ABC PRODUCT EVALUATION REPORT			
		DATE DECEMBER 31, 2024	REV. 1	FOR PUBLICATION ISSUE	CB APP
DRAWING NO. 6034-SK1	SHEET NO. 4 OF 9	SCALE NOT TO SCALE	DES. CB	DRN. JJ	CHK. CB

DRAWING FOR ENGINEERING
EVALUATION
REPORT: 0093-15-3-6034

NOT FOR USE AS
CONSTRUCTION DESIGN
DOCUMENTS



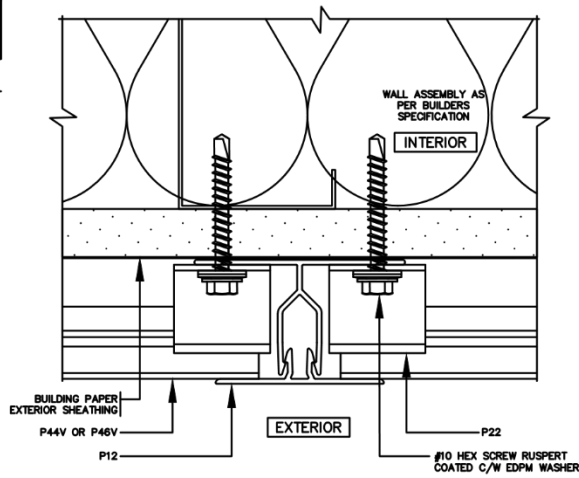

A
5 2-PC VERTICAL TRIM
NOT-TO-SCALE

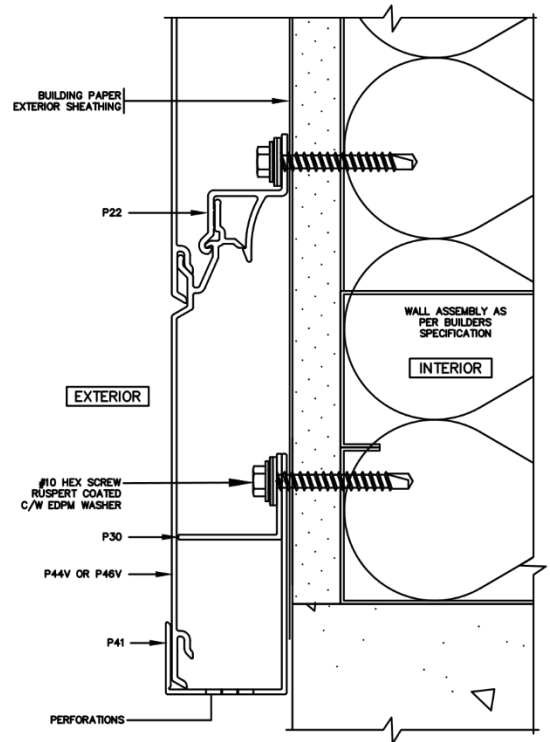

B
5 PERFORATED STARTER J TRIM
NOT-TO-SCALE

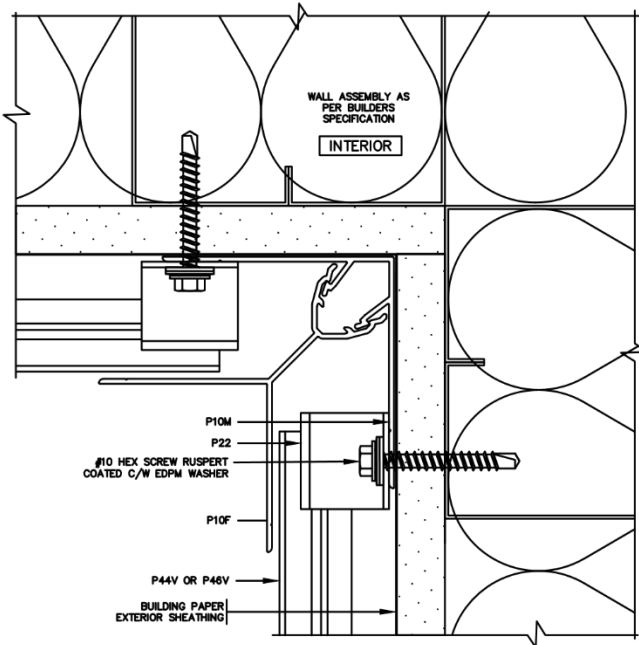

C
5 INSIDE CORNER TRIM DETAIL
NOT-TO-SCALE

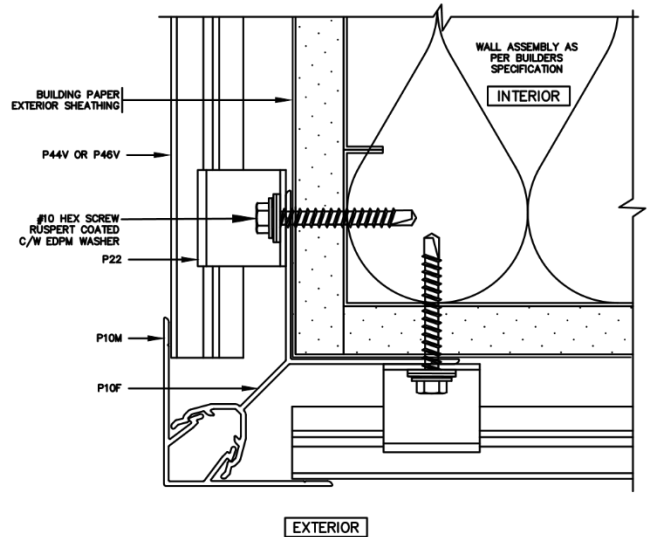

D
5 OUTSIDE CORNER TRIM DETAIL
NOT-TO-SCALE

COPYRIGHT © 2024 RESERVED. THESE PLANS AND DESIGNS ARE AT ALL TIMES THE PROPERTY OF BOCA ENGINEERING TO BE USED FOR THE PROJECT SHOWN. WRITTEN CONSENT IS REQUIRED FROM THE ENGINEER BEFORE ANY REPRODUCTION.

TITLE GENERAL INSTALLATION ASSEMBLY DIAGRAMS	CLIENT ENGAGE BUILDING PRODUCTS FASTPLANK SYSTEMS	PROJECT FASTPLANK SIDING AND SOFFIT NBCC/BCBC/OBC/ABC PRODUCT EVALUATION REPORT
BOCA ENGINEERING CO. SPAR STRUCTURAL & CIVIL CONSULTANTS	DATE DECEMBER 31, 2024	REV. 1
	DRAWING NO. 6034-SK1	SHEET NO. 5 OF 9

FOR PUBLICATION		CB
ISSUE		APP
SCALE NOT TO SCALE	DES. CB	DRN. JJ
	CHK. CB	

DRAWING FOR ENGINEERING
EVALUATION
REPORT: 0093-15-3-6034

NOT FOR USE AS
CONSTRUCTION DESIGN
DOCUMENTS

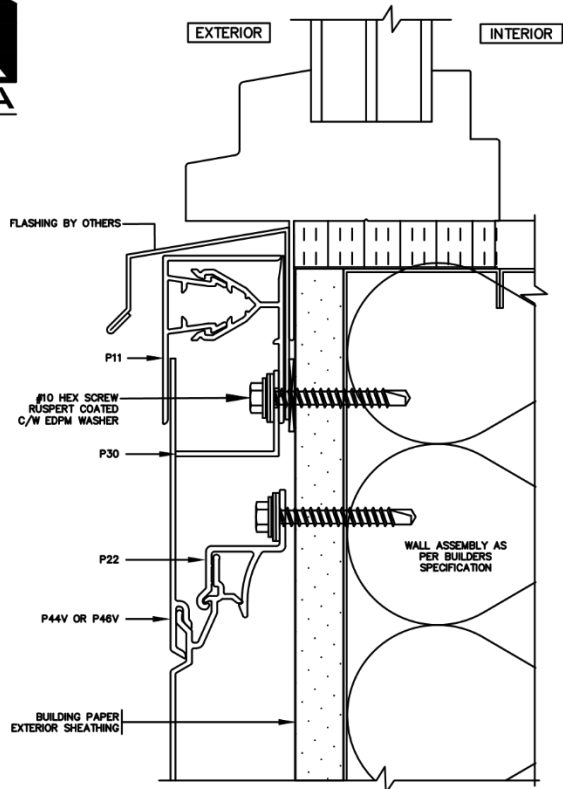

A
6 2-PC J TRIM WINDOW SILL
NOT-TO-SCALE

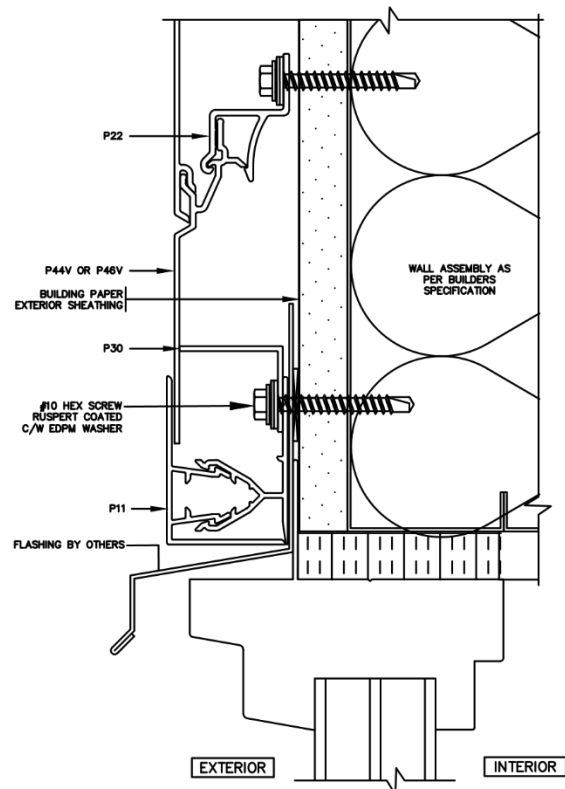

B
6 2-PC J TRIM WINDOW HEAD
NOT-TO-SCALE

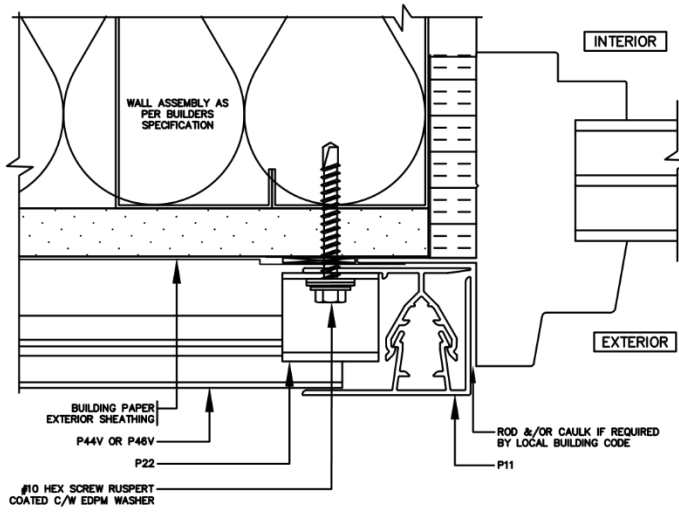

C
6 2-PC J TRIM WINDOW JAMB
NOT-TO-SCALE

COPYRIGHT © 2024 RESERVED. THESE PLANS AND DESIGNS ARE AT ALL TIMES THE PROPERTY OF BOCA ENGINEERING TO BE USED FOR THE PROJECT SHOWN. WRITTEN CONSENT IS REQUIRED FROM THE ENGINEER BEFORE ANY REPRODUCTION.

TITLE GENERAL INSTALLATION ASSEMBLY DIAGRAMS	CLIENT ENGAGE BUILDING PRODUCTS FASTPLANK SYSTEMS	PROJECT FASTPLANK SIDING AND SOFFIT NBCC/BCBC/OBC/ABC PRODUCT EVALUATION REPORT				
		DATE DECEMBER 31, 2024	REV. 1	FOR PUBLICATION	CB	
BOCA ENGINEERING CO. SPAR STRUCTURAL & CIVIL CONSULTANTS	DRAWING NO. 6034-SK1	SHEET NO. 6 OF 9	SCALE NOT TO SCALE	DES. CB	DRN. JJ	CHK. CB

DRAWING FOR ENGINEERING EVALUATION
REPORT: 0093-15-3-6034

NOT FOR USE AS CONSTRUCTION DESIGN DOCUMENTS

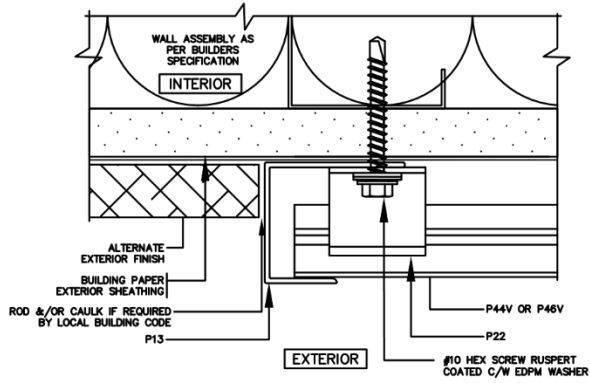

A
7
GENERAL J VERTICAL TERMINATION
NOT-TO-SCALE

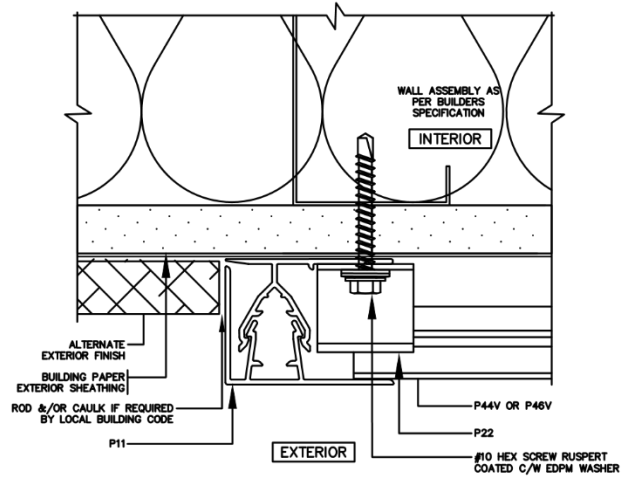

B
7
2-PC J VERTICAL TERMINATION
NOT-TO-SCALE

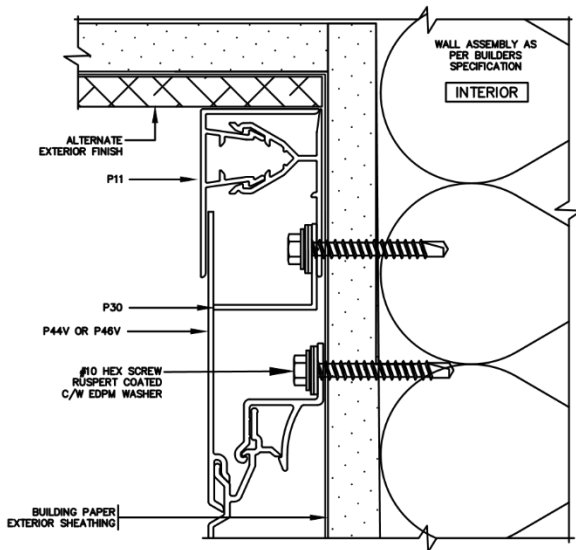

C
7
2-PC J SOFFIT TERMINATION
NOT-TO-SCALE

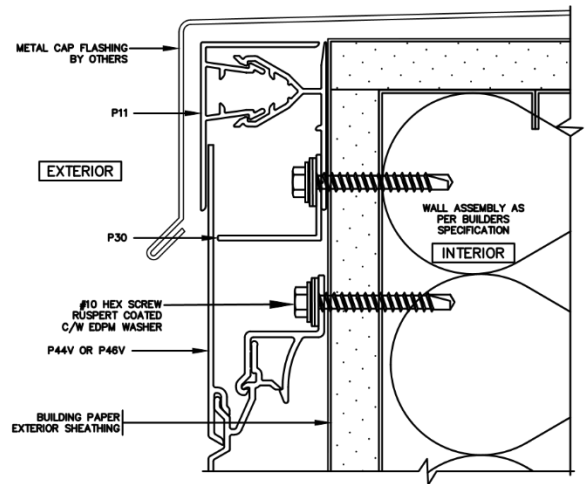

D
7
2-PC J PARAPET TERMINATION
NOT-TO-SCALE

COPYRIGHT © 2024 RESERVED. THESE PLANS AND DESIGNS ARE AT ALL TIMES THE PROPERTY OF BOCA ENGINEERING TO BE USED FOR THE PROJECT SHOWN. WRITTEN CONSENT IS REQUIRED FROM THE ENGINEER BEFORE ANY REPRODUCTION.

TITLE GENERAL INSTALLATION ASSEMBLY DIAGRAMS	CLIENT ENGAGE BUILDING PRODUCTS FASTPLANK SYSTEMS	PROJECT FASTPLANK SIDING AND SOFFIT NBCC/BCBC/OBC/ABC PRODUCT EVALUATION REPORT
BOCA ENGINEERING CO. SPAR STRUCTURAL & CIVIL CONSULTANTS	DATE DECEMBER 31, 2024	REV. 1
	DRAWING NO. 6034-SK1	SHEET NO. 7 OF 9

FOR PUBLICATION		CB
ISSUE		APP
SCALE NOT TO SCALE	DES. CB	DRN. JJ
	CHK. CB	

DRAWING FOR ENGINEERING
EVALUATION
REPORT: 0093-15-3-6034

NOT FOR USE AS
CONSTRUCTION DESIGN
DOCUMENTS

TOP OF DOCUMENT



FASTPLANK SIDING AND SOFFIT END OF WALL WITH SOFFIT DETAILS

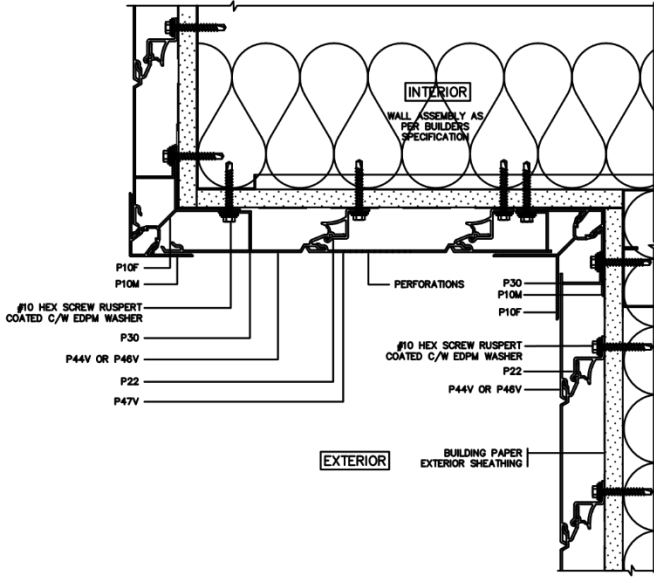

A
8
SOFFIT W/ INSIDE & OUTSIDE CORNER TRIM
NOT-TO-SCALE | ELEVATION

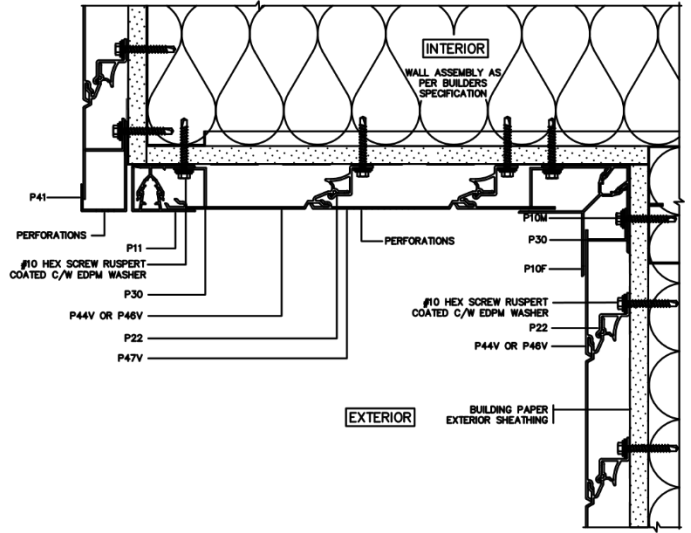

B
8
SOFFIT W/ INSIDE CORNER & 2-PIECE J TRIM
NOT-TO-SCALE | ELEVATION

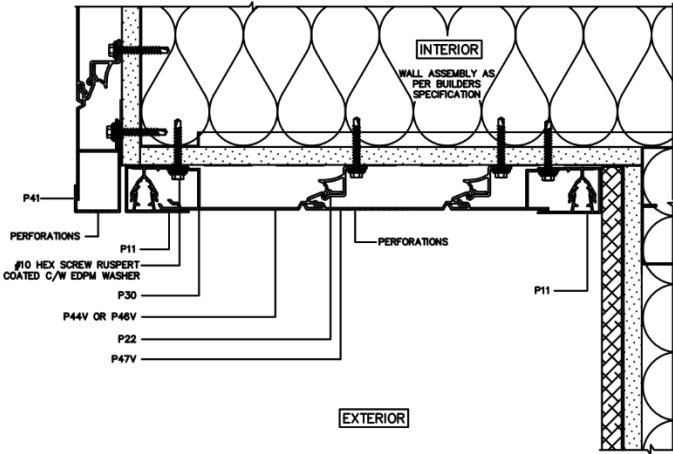

C
8
SOFFIT W/ 2-PIECE J TRIM DETAIL I
NOT-TO-SCALE | ELEVATION

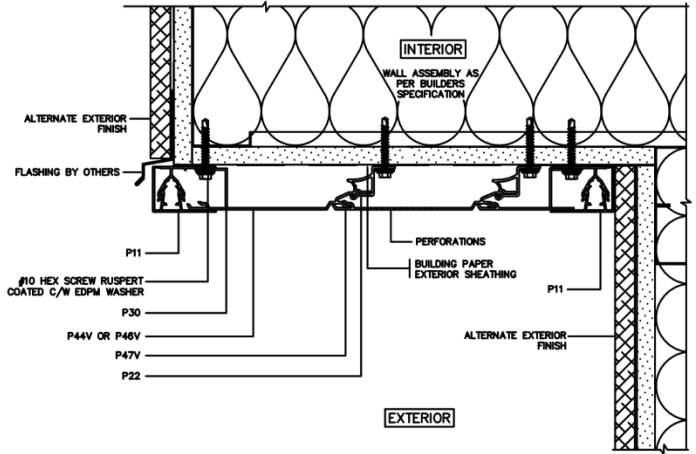

D
8
SOFFIT W/ 2-PIECE J TRIM DETAIL II
NOT-TO-SCALE | ELEVATION

COPYRIGHT © 2024 RESERVED. THESE PLANS AND DESIGNS ARE AT ALL TIMES THE PROPERTY OF BOCA ENGINEERING TO BE USED FOR THE PROJECT SHOWN. WRITTEN CONSENT IS REQUIRED FROM THE ENGINEER BEFORE ANY REPRODUCTION.

TITLE GENERAL INSTALLATION ASSEMBLY DIAGRAMS	CLIENT ENGAGE BUILDING PRODUCTS FASTPLANK SYSTEMS	PROJECT FASTPLANK SIDING AND SOFFIT NBCC/BCBC/OBC/ABC PRODUCT EVALUATION REPORT			DRAWING FOR ENGINEERING EVALUATION REPORT: 0093-15-3-6034	
	DATE DECEMBER 31, 2024	REV. 1	FOR PUBLICATION ISSUE		CB APP	NOT FOR USE AS CONSTRUCTION DESIGN DOCUMENTS
BOCA ENGINEERING CO. SPAR STRUCTURAL & CIVIL CONSULTANTS	DRAWING NO. 6034-SK1	SHEET NO. 8 OF 9	SCALE NOT TO SCALE	DES. CB	DRN. JJ	



TESTING AND CODE COMPLIANCE

1. THE PRODUCT ASSEMBLY SHOWN HAS BEEN EVALUATED ACCORDING TO THE TEST STANDARDS AS OUTLINED IN THE EVALUATION REPORT.
2. THE STRUCTURAL FRAMING AND SHEATHING SHALL BE DESIGNED AND ANCHORED TO PROVIDE LATERAL BRACING AND PROPERLY TRANSFER ALL LOADS TO THE STRUCTURE. FRAMING DESIGN AND INSTALLATION IS THE RESPONSIBILITY OF THE ENGINEER OR ARCHITECT OF RECORD FOR THE PROJECT OF INSTALLATION.
3. THESE DRAWINGS APPLY TO THE TESTING ASSEMBLY ONLY AND DO NOT IMPLY THAT THE SIGNATORY ENGINEER IS THE DESIGNER OF RECORD FOR ANY FUTURE CONSTRUCTION ON WHICH THEY ARE USED.
4. SOME NON-STRUCTURAL COMPONENTS NOT SHOWN AND DO NOT IMPACT STRENGTH FOR ATTACHMENT. TO BE INSTALLED PER CODE AND MAY INCLUDE: FLASHING, INTERIOR INSULATION, INTERIOR FINISH.

INSTALLATION

1. FOR COMPLETE INSTALLATION DETAILS SEE TECHNICAL PRODUCT DATA ON PRODUCT MANUFACTURER'S WEBSITE.
2. THE INSTALLATION DETAILS DESCRIBED ARE OF THE LABORATORY TESTED ASSEMBLY AND MAY NOT REFLECT ACTUAL CONDITIONS FOR A SPECIFIC SITE. IF SITE CONDITIONS DEVIATE FROM THE REQUIREMENTS DETAILED HEREIN, THE JOB ENGINEER OR ARCHITECT PREPARED SITE-SPECIFIC DOCUMENTS SHALL BE USED.

SHEATHING

1. WOOD-BASED STRUCTURAL SHEATHING:
 - 1.1. PLYWOOD – CSA 0121, CSA 0151 OR CSA 0153.
 - 1.2. OSB – CSA 0437.0.
2. GYPSUM SHEATHING: ASTM C1396, EXTERIOR TYPE.

FASTENERS

1. WOOD SCREWS TO CONFORM TO ASME B18.6.1.
2. METAL SCREWS TO CONFORM TO ASTM C1513.
3. ALL FASTENERS WITH CORROSION-RESISTANT RUSPERT COATING.
4. CONCRETE ANCHORS TO CONFORM TO ASTM A307 OR ASTM A36.

FRAMING

1. METAL FRAMING MEMBERS MINIMUM 18 GAUGE U.N.O., 230 MPA, COMPLIANCE WITH CSA S136.
2. WOOD FRAMING MIN. 2x6 S.G. 0.42, COMPLIANCE WITH CSA 0141.

ALUMINUM

1. ALUMINUM TO CONFORM TO CGSB 93.1/93.2 AND CSA S157.

CONCRETE WALLS

1. ALL CONCRETE SHALL BE NORMAL WEIGHT CONTROLLED CONCRETE AND COMPLY WITH CSA A23.3 AND PROVINCIAL BUILDING CODE.
2. CONCRETE WALLS TO HAVE A MINIMUM 28-DAY COMPRESSIVE STRENGTH OF 20 MPA AND COMPLY WITH CSA A23.3 DESIGN OF CONCRETE STRUCTURES.

CONCRETE MASONRY UNIT (CMU) WALLS

1. MASONRY WALL CONSTRUCTION SHALL CONFORM TO THE LOCAL PROVINCIAL BUILDING CODE AND CSA S304 AND SHALL HAVE A MINIMUM 28-DAY COMPRESSIVE STRENGTH OF 10 MPA.
2. GROUT TO CONFORM CSA A371 AND HAVE A MINIMUM 28-DAY COMPRESSIVE STRENGTH OF 15 MPA.

LEGEND AND SYMBOLS

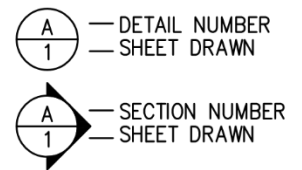

COPYRIGHT © 2024 RESERVED. THESE PLANS AND DESIGNS ARE AT ALL TIMES THE PROPERTY OF BOCA ENGINEERING TO BE USED FOR THE PROJECT SHOWN. WRITTEN CONSENT IS REQUIRED FROM THE ENGINEER BEFORE ANY REPRODUCTION.

 BOCA ENGINEERING CO. SPAR STRUCTURAL & CIVIL CONSULTANTS	CLIENT ENGAGE BUILDING PRODUCTS FASTPLANK SYSTEMS		PROJECT FASTPLANK SIDING AND SOFFIT NBCC/BCBC/OBC/ABC PRODUCT EVALUATION REPORT			
	DATE DECEMBER 31, 2024		REV. 1	FOR PUBLICATION		CB
	DRAWING NO. 6034-SK1	SHEET NO. 9 OF 9	SCALE NOT TO SCALE	DES. CB	DRN. JJ	CHK. CB

DRAWING FOR ENGINEERING
EVALUATION
REPORT: 0093-15-3-6034

NOT FOR USE AS
CONSTRUCTION DESIGN
DOCUMENTS



ATTACHMENT 4: DISCUSSION OF LIMIT STATES DESIGN PROCEDURE

Testing:

The NBCC by reference to CSA S157-17 provides guidance information on how to undertake a testing and engineering design analysis to make determining conclusions to the Code requirements covered in this report. CSA S157-17, Chapter 22, *Testing*, subsection 22.1.1(c) provides the objective statements that directs a design by testing approach for the flexural resistance and attachment of aluminum siding. Subsection 22.2.2, *Procedures*, references the ASTM E330 test procedure. Subsection 22.3.1.2, *Ultimate limit state*, says “the applied force shall be that due to the factored loads... divided by the appropriate resistance factor...” The Code clearly defines the loading criteria for exterior cladding systems.

Load Combinations, Load and Resistance Factors, Test Factors:

Test Load Factors are computed by:

$$\text{Test Load Factor} = \frac{\text{Combined Load Factor}}{\text{Resistance Factor}}$$

The resistance factor is taken from the materials standard for the respective failure type.

Wind load on cladding is typically taken as acting as an isolated and independent force on the cladding component and its attachment into the framing. Design load combinations used in this evaluation are:

Ultimate (ULS): 1.4 W

Service (SLS): (0.75) 1.0 W (where 0.75 is the wind importance factor for serviceability)

The failure mode in all tests performed was disengagement of the aluminum planks from the fastening clips, followed by bending past the yield of the plank members. Following CSA S157, Clause 6.4, the resistance factors for the respective loading/stress conditions of the aluminum components are tabulated and combined with the load factors and the respective minimum test load factors become:

Components	Stress Type	Resistance Factor (Φ)	Ult. Load Factor (L.F.)	L.F / Φ
Planks	Bending (yield)	0.9	1.4	1.56
Fastening Clips	Fastening	0.67	1.4	2.08

By review of the table, it is shown that the appropriate system test factor is 2.0 to the unfactored service-level design loads.

Wall Framing Component Strength of Attachments:

The maximum design wind pressures published in the report are exclusive to the tested strength of the cladding materials and the connection strength into the wall framing. In many cases, the actual design wind pressure would be less than the capacity of the cladding system. In any such and all cases in a building design, the actual design pressure imparted by the cladding into the building framing (and all other forces imparted into the framing) should be used to design the building framing members.

There are many variables that would be considered in the building frame design. The minimum framing members specified in this report to accept the cladding attachment forces would not necessarily adequately serve the overall



building design loads and deflection limits. This is why the design tables and diagrams in the report advise that design capacity of “the building framing is outside the scope of this report and must be designed and installed for the applicable wind, climate and occupancy loads” of the building project. The variables in the framing design, including but not limited to the height of walls, whether they are vertical load-bearing or non-bearing, and the contribution of other climate loads along with the wind force transferred through the cladding, must all be taken in to account when specifying the structural components that the cladding will attach in to.

Deflection Limits:

The bending deflection limits set for this design evaluation are $L/180$ for the deflection of the wall frame, and $L/60$ for the differential movement of the cladding member relative to the wall frame. With these deflection limits tested at the maximum wall height of 10 ft and cladding anchorage spans of 16 or 32 inches, the cladding panels were found to not dislodge or distort and return to the set position after releasing the service-level design loads as published. In-plane lateral deflection limits of the system were not assessed.



ATTACHMENT 5: NATIONAL TO PROVINCIAL CODE CROSS-REFERENCES

BRITISH COLUMBIA: 2024 BCBC

NBCC Div. B Section	BCBC Div. B Section	BCBC Referenced Standard or Div. B Section ¹	Year	BCBC Comparison to NBCC
Part 3/4/5				
1.4.1.2.(1) ²	1.4.1.2.(1) ²	CAN/ULC S114	2018	Article content same as NBCC
3.1.4.8(1)(a)	3.1.4.8(1)(a)	-	-	Article content same as NBCC
3.1.5.1	3.1.5.1	Div A 1.4.1.2	-	Article content same as NBCC
3.1.5.2	3.1.5.2	-	-	Article content same as NBCC
3.1.7.1	3.1.7.1	CAN/ULC-S101	2014	Article content same as NBCC
3.1.12.1(1)	3.1.12.1(1)	CAN/ULC-S102	2010	Article content same as NBCC
3.2.3.16.1 (a)	3.2.3.16.1 (a)	-	-	Article content same as NBCC
4.1.3.5	4.1.3.5	-	-	Article content same as NBCC
4.1.7.1(5)(a)	4.1.7.1(5)(a)	4.1.7.3	-	Article content same as NBCC
4.3.5.1	4.3.5.1	CAN/CSA S157, S157.1	2017	Article content same as NBCC
5.1.4.1	5.1.4.1	5.2.1, 5.2.2, 4.1.3.5	-	Article content same as NBCC
5.1.4.2	5.1.4.2	-	-	Article content same as NBCC
5.2.1.3(3)	5.2.1.3(3)	4.1.7	-	Article content same as NBCC
5.6.1.1	5.6.1.1	-	-	Article content same as NBCC
5.6.2.1	5.6.2.1	-	-	Article content same as NBCC
5.9.1.1(1)(b)	5.9.1.1(1)(b)	CGSB 93.1, 93.2	1985, 1991	Article content same as NBCC
5.9.3.5	5.9.3.5.(2) ³	ASTM E331	2000	Article content same, Section # differs
A-5.9.3.2(1)	A-5.9.3.2(1) ³	ASTM E330	2014	Article content same as NBCC
Part 9				
9.4.1.1(1)(c)(ii)	9.4.1.1(1)(c)(ii)	Part 4	-	Article content same as NBCC
9.10.3.1(1)(a)	9.10.3.1(1)(a)	Part 3	-	Article content same as NBCC
9.10.3.2(1)	9.10.3.2(1)	Part 3	-	Article content same as NBCC
9.10.6.1	9.10.6.1	3.1.5	-	Article content same as NBCC
9.10.12.4 (3)(a)	9.10.12.4 (3)(a)	-	-	Article content same as NBCC
9.27.1.1(1)	9.27.1.1(1)	9.27.2 – 9.27.12, Part 5	-	Article content same as NBCC
9.27.2.2(1)(a)	9.27.2.2(1)(a)	-	-	Article content same as NBCC
9.27.11.1	9.27.11.1	CGSB 93.1, 93.2	1985, 1991	Article content same as NBCC

1. Only the applicable reference standards and code sections cited in the main body text are listed. (-) indicates that the main body text covers the full explanation of the objective.
2. Definition appears in Div A.
3. Section 5.9.3 Reserved, Div B. Section 1.3 Referenced Documents and Organizations calls out ASTM E330 / ASTM E331 in code references A-5.9.3.2.(1) / 5.9.3.5.(2), respectively.



ONTARIO: 2024 OBC [Last Revision: May 2024]

NBCC Div. B Section	OBC Div. B Section	OBC Referenced Standard or Div. B Section ¹	Year	OBC Comparison to NBCC
Part 3/4/5				
1.4.1.2.(1) ²	1.4.1.2.(1) ²	CAN/ULC S114	2018	Article content same, referenced standard year differs
3.1.4.8(1)(a)	3.1.4.8(1)(a)	-	-	Article content same as NBCC
3.1.5.1	3.1.5.1	Div A 1.4.1.2	-	Article content same as NBCC
3.1.5.2	3.1.5.2	-	-	Article content same as NBCC
3.1.7.1	3.1.7.1	CAN/ULC-S101	2014	Article content same as NBCC
3.1.12.1(1)	3.1.12.1(1)	CAN/ULC-S102	2010	Article content same as NBCC
3.2.3.16.1 (a)	3.2.3.16.1 (a)	-	-	Article content same as NBCC
4.1.3.5	4.1.3.5	-	-	Article content same as NBCC
4.1.7.1(5)(a)	4.1.7.1(5)(a)	4.1.7.3	-	Article content same as NBCC
4.3.5.1	4.3.5.1	CAN/CSA S157, S157.1	2017	Article content same, referenced standard year differs
5.1.4.1	5.1.4.1	5.2.1, 5.2.2, 4.1.3.5	-	Article content same as NBCC
5.1.4.2	5.1.4.2	-	-	Article content same as NBCC
5.2.1.3(3)	5.2.1.3(3)	4.1.7	-	Article content same as NBCC
5.6.1.1	5.6.1.1	-	-	Article content same as NBCC
5.6.2.1	5.6.2.1	-	-	Article content same as NBCC
5.9.1.1(1)(b)	5.10.1.1(1)b	CGSB 93.1, 93.2	1985, 1991	Article content same, Section # differs
5.9.3.5	5.10.4.5(2)(a)	ASTM E331	2000	Article content same, Section # differs
A-5.9.3.2(1)	-	-	-	Article does not exist in OBC
Part 9				
9.4.1.1(1)(c)(ii)	9.4.1.1(1)(c)(ii)	Part 4	-	Article content same as NBCC
9.10.3.1(1)(a)	9.10.3.1(1)	Part 3	-	Article content same, Section # differs
9.10.3.2(1)	9.10.3.2(1)	Part 3	-	Article content same as NBCC
9.10.6.1	9.10.6.1	3.1.5	-	Article content same as NBCC
9.10.12.4 (3)(a)	9.10.12.4 (3)(a)	-	-	Article content same as NBCC
9.27.1.1(1)	9.27.1.1(1)	9.27.2 – 9.27.12, Part 5	-	Article content same as NBCC
9.27.2.2(1)(a)	9.27.2.2	-	-	Article content is reserved in OBC
9.27.11.1	9.27.11.1	CGSB 93.1, 93.2	1985, 1991	Article content same as NBCC

1. Only the applicable reference standards and code sections cited in the main body text are listed. (-) indicates that the main body text covers the full explanation of the objective.
2. Definition appears in Div A.



ALBERTA: 2023 NBC (AE)

NBCC Div. B Section	NBC (AE) Div. B Section	NBC (AE) Referenced Standard or Div. B Section ¹	Year	NBC (AE) Comparison to NBCC
Part 3/4/5				
1.4.1.2.(1) ²	1.4.1.2.(1) ²	CAN/ULC S114	2018	Article content same as NBCC
3.1.4.8(1)(a)	3.1.4.8(1)(a)	-	-	Article content same as NBCC
3.1.5.1	3.1.5.1	Div A 1.4.1.2	-	Article content same as NBCC
3.1.5.2	3.1.5.2	-	-	Article content same as NBCC
3.1.7.1	3.1.7.1	CAN/ULC-S101	2014	Article content same as NBCC
3.1.12.1(1)	3.1.12.1(1)	CAN/ULC-S102	2010	Article content same as NBCC
3.2.3.16.1 (a)	3.2.3.16.1 (a)	-	-	Article content same as NBCC
4.1.3.5	4.1.3.5	-	-	Article content same as NBCC
4.1.7.1(5)(a)	4.1.7.1(5)(a)	4.1.7.3	-	Article content same as NBCC
4.3.5.1	4.3.5.1	CAN/CSA S157, S157.1	2017	Article content same as NBCC
5.1.4.1	5.1.4.1	5.2.1, 5.2.2, 4.1.3.5	-	Article content same as NBCC
5.1.4.2	5.1.4.2	-	-	Article content same as NBCC
5.2.1.3(3)	5.2.1.3(3)	4.1.7	-	Article content same as NBCC
5.6.1.1	5.6.1.1	-	-	Article content same as NBCC
5.6.2.1	5.6.2.1	-	-	Article content same as NBCC
5.9.1.1(1)(b)	5.9.1.1(1)(b)	CGSB 93.1, 93.2	1985, 1991	Article content same as NBCC
5.9.3.5	5.9.3.5	ASTM E331	2000	Article content same as NBCC
A-5.9.3.2(1)	A-5.9.3.2(1)	ASTM E330	2014	Article content same as NBCC
Part 9				
9.4.1.1(1)(c)(ii)	9.4.1.1(1)(c)(ii)	Part 4	-	Article content same as NBCC
9.10.3.1(1)(a)	9.10.3.1(1)(a)	Part 3	-	Article content same as NBCC
9.10.3.2(1)	9.10.3.2(1)	Part 3	-	Article content same as NBCC
9.10.6.1	9.10.6.1	3.1.5	-	Article content same as NBCC
9.10.12.4 (3)(a)	9.10.12.4 (3)(a)	-	-	Article content same as NBCC
9.27.1.1(1)	9.27.1.1(1)	9.27.2 – 9.27.12, Part 5	-	Article content same as NBCC
9.27.2.2(1)(a)	9.27.2.2(1)(a)	-	-	Article content same as NBCC
9.27.11.1	9.27.11.1	CGSB 93.1, 93.2	1985, 1991	Article content same as NBCC

1. Only the applicable reference standards and code sections cited in the main body text are listed. (-) indicates that the main body text covers the full explanation of the objective.
2. Definition appears in Div A.

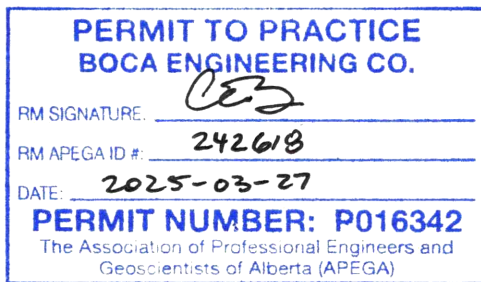

Permit to Practice

<END>